



AREA SEPARATION WALLS (ASW) FOR A ROW HOUSE WITH SECONDARY SUITES Policy B19-03

For a row house building constructed per NBC2019(AE):B:9.10.15. containing more than 2 Houses with a secondary suite,

POLICY:

Area Separation Walls (ASW) with non-loadbearing minimum 3/4h fire-resistance-rated wood-frame sacrificial protective walls are deemed to meet the intent of firewalls for NBC2019(AE):Div B: 9.10.11.2.(2).

PURPOSE:

This policy addresses a party wall construction option for Part 9 row houses constructed per National Building Code-2019 Alberta Edition (NBC2019(AE)) containing more than 2 houses with a secondary suite.

NBC2019(AE): Division B: 9.10.11.2.(2) requires that where a party wall separates any 2 adjacent (but not necessarily adjoining) houses with a secondary suite from the rest of the building, the party wall shall be constructed as a firewall to create separate buildings each containing no more than 2 adjacent houses with a secondary suite. All references are to Division B of National Building Code-2019 Alberta Edition (NBC2019(AE)) unless otherwise noted.

Firewalls have historically been constructed of either masonry block or solid concrete. NBC2019(AE) allows 2h fire-resistance rated firewalls to be constructed of other noncombustible materials. For the purpose of this policy, a row house containing or intended to contain

- three units, each being a house with a secondary suite, or
 - more than three units, with at least three units being a house with a secondary suite,
- may use tested gypsum shaftliner system firewalls with sacrificial protective wood-frame walls, altogether referred to as Area Separation Walls (ASW), for any firewall required per 9.10.11.2.(2).

The policy describes an acceptable construction option deemed to provide a level of protection and performance equal or better than prescriptive solutions found in NBC2019(AE), applicable to freehold or condominium lots. It is not the intention that this policy limit design choices or preclude other solutions, as other options are available to permit applicants. For example, loadbearing sacrificial protective wall systems may be accepted with engineering review and consideration of parapets, combustible projections, etc., per NBC(AE).

PROCEDURE:

Except as required or allowed by this Policy, Area Separation Walls (ASW) serving as firewalls in Part 9 row houses are to be designed and installed per the manufacturer's specifications, extending continuously and vertically from the foundation to the roof including through all projections and concealed spaces, including in attached garages. Do not penetrate the ASW except for piping, tubing, wiring and metal conduit sealed by an approved 2h FT-rated fire stop system. An ASW is not intended to serve as a shear wall. UL-listed systems currently deemed acceptable for use with this policy: W311, W312, W314, U336, U347, U366, U373, U375, U388. Published values for these assemblies exceed STC 60.

1. PRINT, COMPLETE AND SUBMIT 'PRE-CONSTRUCTION' PORTION of LETTER WITH BUILDING PERMIT APPLICATION

2. COMPLETE AND EMAIL AS-BUILT COMPLIANCE LETTER to BuildingIC@edmonton.ca BEFORE REQUEST FOR FINAL INSPECTION

The following diagrams represent general acceptable configurations for ASW for this policy. Any deviation is to be discussed with the plans examiner before permit issuance, and may result in an alternative solution which may require professional third party involvement.

1. AREA SEPARATION WALL ASSEMBLY

- ① **Minimum 15.9mm(5/8") Type "X" gypsum board** continuous through rooms, attic-roof space and concealed space side of walls, finished per 9.29.5. and penetrations limited per 9.10.9.6.
- ② **Non-loadbearing** min 38x89mm @ ≤600mmOC (2"x4" @ ≤24"OC) sacrificial wood-frame protective wall with batt insulation filling stud spaces. No columns or beams may be located within protective walls. The batt insulation of minimum nominal R12 over entire wall area results in equal or better performance compared to the firewall insulation requirement of 9.36.2.5.(2)
- ③ 19mm (3/4") air space
- ④ Two layers 25.4mm (1") gypsum board shaftliner (nom 610mm (24") width) of the UL-listed system used
- ⑤ "H" studs of the UL-listed system used; ("C" runners of the UL-listed system used are not shown)
- ⑥ **Saw kerf** approximately 1/2 depth of subfloor / roof sheathing to facilitate break-away
- ⑦ Aluminum attachment/detachment clip of the UL-listed system used
- ⑧ Depicts continuity of protective wall where floor joist running parallel to ASW

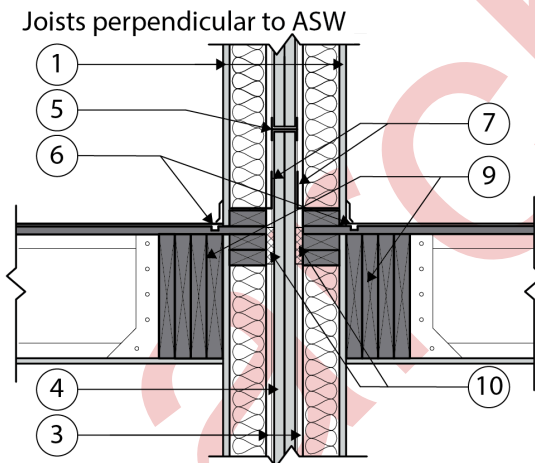

- ⑨ Depicts continuity of protective wall and that beams and columns not permitted within the ASW assembly

2. ROOF/ATTIC SPACE and PARAPET

Roof parapets required per 3.1.10.4.(1)(a) **may be omitted** where ASW 'firewall plane' to 'roof plane' intersections are constructed as follows:

- ⑩ Fire blocking of air space per 9.10.16.3.(3)

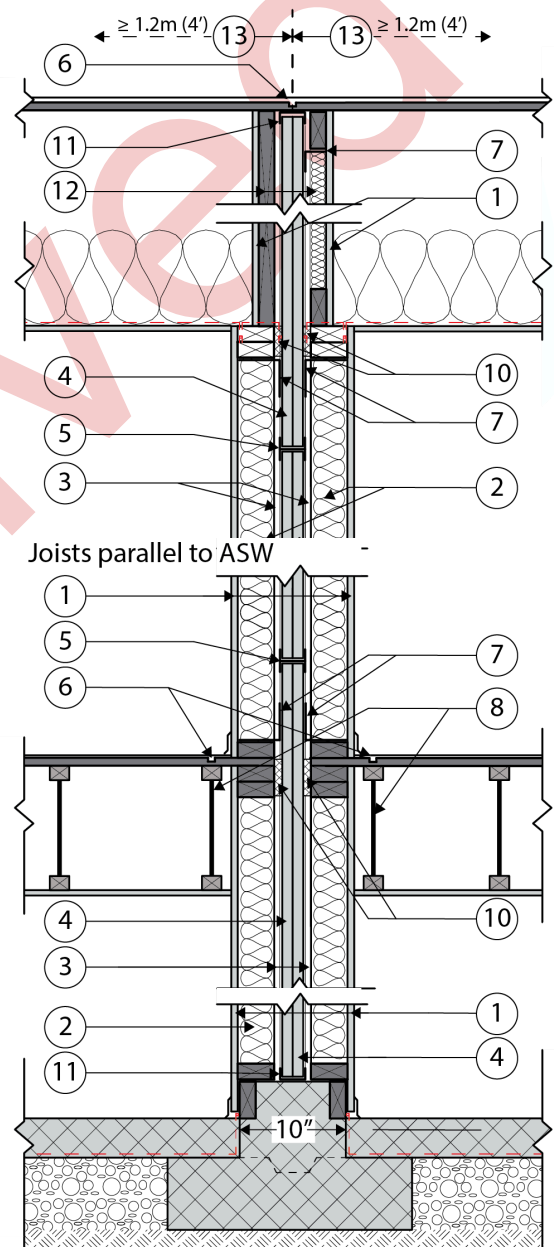

- 11 UL-listed system used: "C" runner/ "H" studs / shaftliner gypsum; extends vertically without offset to the upper roof level if the 2 roofs are at different elevations
- 12 **Non-loadbearing / structural** roof truss, or rafter/roof joist with minimum 38x89mm @ ≤600mmOC (min 2"x4" @ ≤24"OC) vertical blocking, with **batt insulation** filling spaces, and **minimum 15.9mm (½") Type "X"** gypsum board, fire taped. Bracing and blocking is not to penetrate the protective walls
- 13 Roof sheathing with a flame-spread rating ≤25, when tested per CAN/ULC-S102, on its downward-facing surface for ≥1.2m (4') each side of the plane of the firewall; any space between the top of the firewall and the roof sheathing filled with mineral wool or noncombustible material tightly fitted in and joints sealed with fire sealant

3. COMBUSTIBLE PROJECTIONS

No combustible material may extend across the end of a firewall. Walls at an angle of less than 135 degrees, measured from the exterior of the building, and parallel walls may have additional requirements per 3.2.3.14.; see below-Section 4.

- 14 Exterior wall framing and wall sheathing is to be **discontinuous** at the plane of the firewall, with the shaftliner component (similar to 4, 5 and 11 above) extending through to the exterior plane of the wall sheathing and any eaves and concealed spaces
- 15 Combustible projections, including balconies, platforms and stairs, eaves and canopies are not permitted within 2.4m (8') of combustible projections and window and door openings on the other side of the firewall, per 3.1.10.7.(2). Noncombustible structures are permissible.
Exception to this: eave projections and canopy structures within 2.4m (8') of such projections on the other side of the firewall may be constructed with
 - a. fascia or barge board of either noncombustible material or fire-retardant treated wood (pressure impregnated with fire-retardant chemicals (eg., D-Blaze FRTW), and
 - b. soffit bottom and ends enclosed enclosed with ≥12.5mm (½") exterior-grade gypsum board on blocking @ ≤600mmOC (≤24"OC)

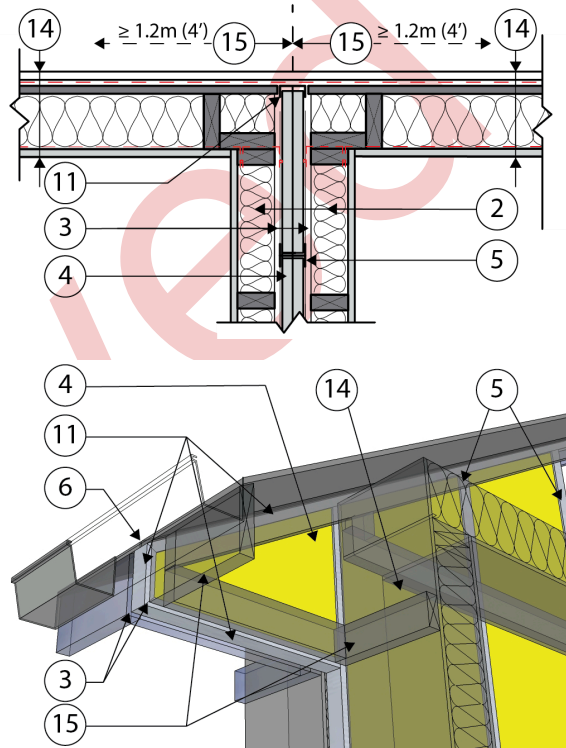

4. EXTERNAL WALLS THAT MEET AT A FIREWALL Walls that meet at an angle of <135 degrees, measured from the exterior of the building, and parallel walls may have additional requirements per 3.2.3.14.

- 16 ASW continuous per 3.1.10.3 with no combustible material extending across the ASW per 3.1.10.7.(1)
- 17 Unprotected opening (window or door)

(continued next page...)

1. PRINT, COMPLETE AND SUBMIT 'PRE-CONSTRUCTION' PORTION of LETTER WITH BUILDING PERMIT APPLICATION
2. COMPLETE AND EMAIL AS-BUILT COMPLIANCE LETTER to BuildingIC@edmonton.ca BEFORE REQUEST FOR FINAL INSPECTION

No unprotected opening in either wall

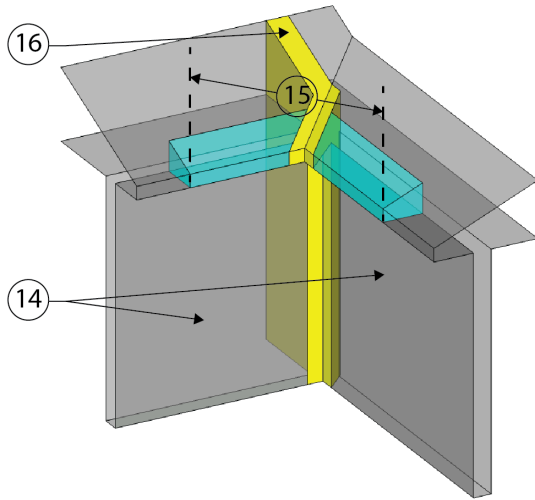

Unprotected opening(s) in one wall

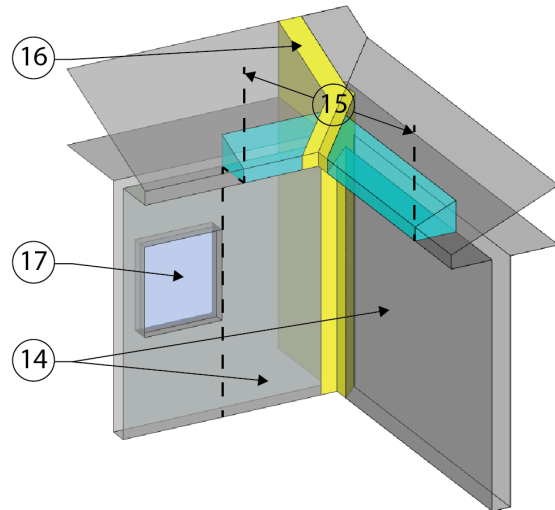

18 Minimum distance D_o , per 3.2.3.14 & A-3.2.3.14.(1)

19 2h fire-rated exterior walls within D_o shown per 18 by installation of minimum 2 layers of 15.9mm(5/8") Type "X" gypsum board on interior side of wall.

Demonstration Example: $2\text{m} \times 2\text{m} = 4\text{m}^2$

Fire Compartment 'A':

Exposing Building Face: $3\text{m} \times 10\text{m} = 30\text{m}^2$

Unprotected opening: 17 $2\text{m} \times 2\text{m} = 4\text{m}^2$

$4\text{m}^2/30\text{m}^2 = 13.3\%$

per Table 9.10.15.4.: Limiting Distance $D = 2.1\text{m}$

Fire Compartment 'B':

Exposing Building Face: $3\text{m} \times 13.3\text{m} = 40\text{m}^2$

Unprotected opening: 17 $2\text{m} \times 2\text{m} = 4\text{m}^2$

$4\text{m}^2/40\text{m}^2 = 10\%$

per Table 9.10.15.4.: Limiting Distance $D = 1.9\text{m}$

$D_o = 2D - (\theta/90 \times D)$; $D_o = 2(2.1\text{m}) - (90/90 \times 2.1\text{m})$; $D_o =$

$4.2\text{m} - (1 \times 2.1\text{m})$; **$D_o = 2.1\text{m}$**

(see A-3.2.3.14.(1) for more examples, including for parallel walls)

Unprotected openings in both walls

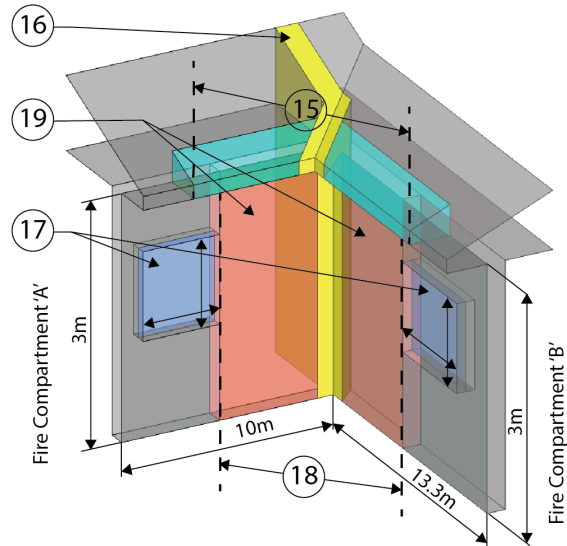

5. OPERATIONAL CONTROL

A permanent sign, as follows, is to be prominently posted in all mechanical rooms within each unit of the row house, reminding occupants of obligation to maintain the integrity of firewalls in their home.

TO MAINTAIN ESSENTIAL FIRE SEPARATIONS
DO NOT DRILL, CUT OR DAMAGE THE PARTY WALL
BETWEEN THIS UNIT AND THE NEIGHBOURING UNIT(S).
PROFESSIONALLY REPAIR ANY DAMAGE IMMEDIATELY.

1. PRINT, COMPLETE AND SUBMIT 'PRE-CONSTRUCTION' PORTION of LETTER WITH BUILDING PERMIT APPLICATION

2. COMPLETE AND EMAIL AS-BUILT COMPLIANCE LETTER to BuildingIC@edmonton.ca BEFORE REQUEST FOR FINAL INSPECTION

6. LETTER OF CONSTRUCTION INTENTION. The first section of the letter, provided near the end of this document, is to be completed and submitted with the permit application. Include details of this policy in the plans and specifications for trades guidance.

7. LETTER OF COMPLIANCE. The second section of the letter, provided near the end of this document, is to be completed and submitted for review and filing prior to request for final building inspection for occupancy.

Notes:

Where two parties share a wall on a property line, each is responsible for fire safety in their unit, but is still subject to possible fire risks from activities in adjoining units. A separating firewall is intended to provide a significant degree of fire protection between adjacent units. Firewall construction in Part 9 is guided by Part 3, through 9.10.11.3. As well as traditional masonry or concrete fire walls, an Area Separation Wall assembly may provide the required fire-resistance rating while also resisting physical damage that may compromise firewall performance. Such damage may arise out of normal use, or falling debris or structural collapse in a fire.

Damage protection for a firewall may be provided by a single fire- and damage-resistant material (eg, cast concrete), or in the case of ASW by separate components, one for fire resistance and another for damage protection. The sacrificial wall is intended to provide adequate damage protection until firefighter intervention and suppression begins in the relatively small unsprinklered fire compartments that comprise typical row houses. In the context of ASWs in row houses in Edmonton, reasonable and reliable time frames for FRS response and suppression activity, and consequences of failure rate/level resulting in meaningful mechanical damage to the firewall in that time frame are considered.

The ASW separation configuration is intended to extend through any attached garage and its attic and roof spaces and concealed spaces in the same manner as described in this document. Detached garages that may span a property line are not included in this document, as they do not contain secondary suites and traditional party wall separation construction is an adequate minimum in typical cases.

Also taken into consideration is the successful use of these systems for decades in row houses in the USA, and reliance on the time-tested and proven characteristics of these listed systems with respect to their expected performance to meet intent of 9.10.11.2.(2).

In considering the loadbearing protective wall argument and shaftliner firewall protection resulting from failure and collapse of building framing components in a fire compartment reasonably foreseeably compromising the shaftliner firewall, this policy does **not** address loadbearing protective sacrificial walls. Though it is the shaftliner and not the protective walls which is subject to the load-restriction factor of 0.82 per BXUV7, the potential complexity of bearing wall, beam and column configurations adjacent the shaftliner that are not readily captured in a generic solution means that at this time this policy is restricted to non-loadbearing protective walls.

The Letter of Construction Intention and background documentation is to be submitted with the building permit application and will be managed as a **variance**. A Compliance Declaration for the work related to firewall(s) is to be submitted to BuildingIC@edmonton.ca in advance of request for final building inspection, to provide confirmation from the owner/permit holder that all elements of the ASW, including those that were not able to be audited during regular building inspection, were incorporated into the construction.

In exceptional circumstances, a safety codes officer may refuse to issue a building permit that incorporates the policy; the permit applicant will be notified of reason for refusal. Non-compliance with requirements of a variance is an offence.

Disclaimer: The information in this letter is not intended to provide professional design advice, and may not address all conditions on a project. If professional expertise is required with respect to an issue or circumstance, the services of a professional should be sought.

1. PRINT, COMPLETE AND SUBMIT 'PRE-CONSTRUCTION' PORTION of LETTER WITH BUILDING PERMIT APPLICATION
 2. COMPLETE AND EMAIL AS-BUILT COMPLIANCE LETTER to BuildingIC@edmonton.ca BEFORE REQUEST FOR FINAL INSPECTION

City of Edmonton
 Development Services Branch
 Safety Codes, Permits and Inspections

3rd Floor, Edmonton Tower
 10111 104 Avenue NW
 Edmonton AB T5J 0J4
edmonton.ca or 311



Project City File #
 and/or
 Address _____

Area Separation Walls (ASW) for a Row House with secondary suites

to: City of Edmonton
 Safety Codes Permits and Inspections
 3rd Floor, 10111 – 104 AVE NW
 Edmonton, AB T5J 0J4

Letter of Construction Intention re: Policy B19-03

Pre-construction Declaration, to be submitted with building permit application:

I, (PRINT NAME) _____ affirm this _____ day of _____ 202__

that

- I am the owner or owner's authorized agent of the above-noted property;
- by providing this letter, I confirm I have reviewed this 'Area Separation Walls (ASW) for a Row House with secondary suites' Policy B19-03 document;
- I give assurance that the proposed Area Separation Wall(s) at the above project address will be constructed in accordance with the manufacturer's specifications, National Building Code-2019 Alberta Edition (NBC2019(AE)), and this policy in lieu of requesting an alternative solution; and
- I confirm that the policy document together with submitted plans, documents and details contain sufficient details to demonstrate conformance with NBC2019(AE):Division C:2.2.5.2., and I will notify the City of Edmonton if the approved construction intention is modified during the *project*.

THIS IS NOT A BUILDING PERMIT OWNER/AUTHORIZED AGENT SIGNATURE: _____

Letter of Construction Compliance re: Policy B19-03

As-built Compliance Declaration, to be submitted prior to request for final inspection for occupancy:

I, (PRINT NAME) _____ affirm this _____ day of _____ 202__

that

- I am the owner or owner's authorized agent of the above noted property; and
- I confirm all 'Area Separation Walls (ASW) for a Row House with secondary suites' were constructed per manufacturer's specifications for UL-listed ASW Design # _____, NBC2019(AE), and Policy B19-03.

THIS IS NOT PERMISSION TO OCCUPY. OWNER/AUTHORIZED AGENT SIGNATURE: _____

NBC2019(AE):C:2.2.5.2. Information Required on Drawings and Specifications

1) Information shown on drawings and in specifications shall be clear and legible, and shall contain sufficient details to demonstrate conformance with this Code. (See A-2.2.6.2.(1) in Appendix A.)

NBC2019(AE):C:2.2.10.9. Responsibility for Compliance

1) Neither the issuance of a *permit* nor inspections made by the *authority having jurisdiction* shall in any way relieve the *owner* of a *building* from full responsibility for carrying out the construction or having the construction carried out in accordance with the requirements of the Safety Codes Act and regulations made pursuant to that Act, this Code, or the *permit*, including compliance with any special conditions required by the *authority having jurisdiction*.

NBC2019(AE):C:2.2.13.6. Verification of Compliance

1) Except as required in Article 2.4.3.2., when required by the *authority having jurisdiction*, an *owner* or a *constructor* shall provide written assurance from the person supervising construction that the construction was in compliance with the requirements of this Code and any *permits* issued.