

**2-3% OVERALL LOT SLOPE
TYPE A0 - ZERO LOT LINE
REAR TO FRONT DRAINAGE**
- CONNECT HOUSE AND GARAGE ROOF LEADERS TO STORM SERVICES

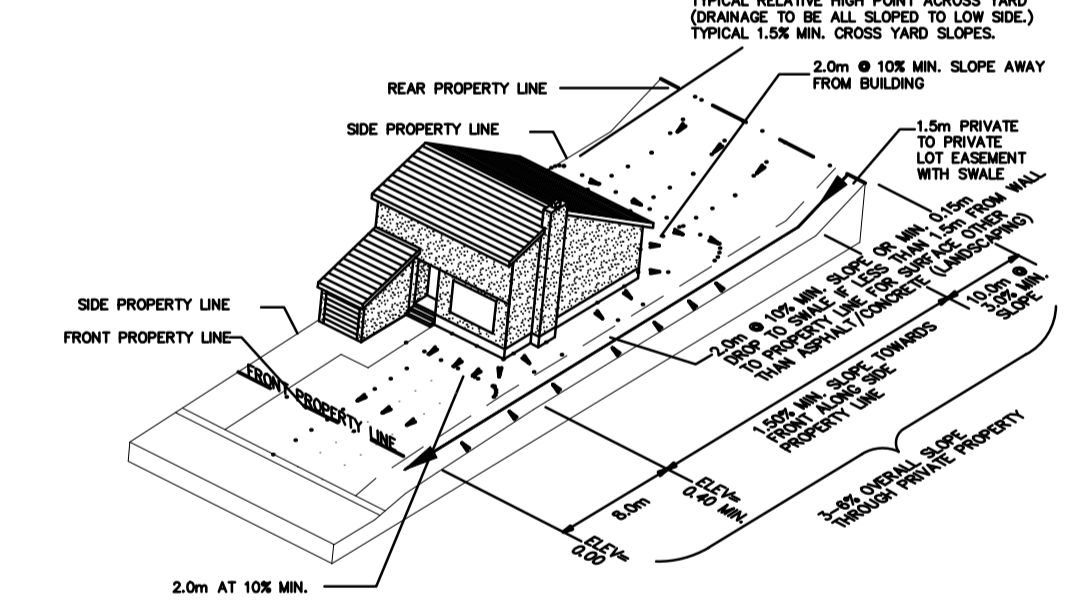

**3-6% OVERALL LOT SLOPE
TYPE B0 - ZERO LOT LINE
REAR TO FRONT DRAINAGE**
- CONNECT HOUSE AND GARAGE ROOF LEADERS TO STORM SERVICES

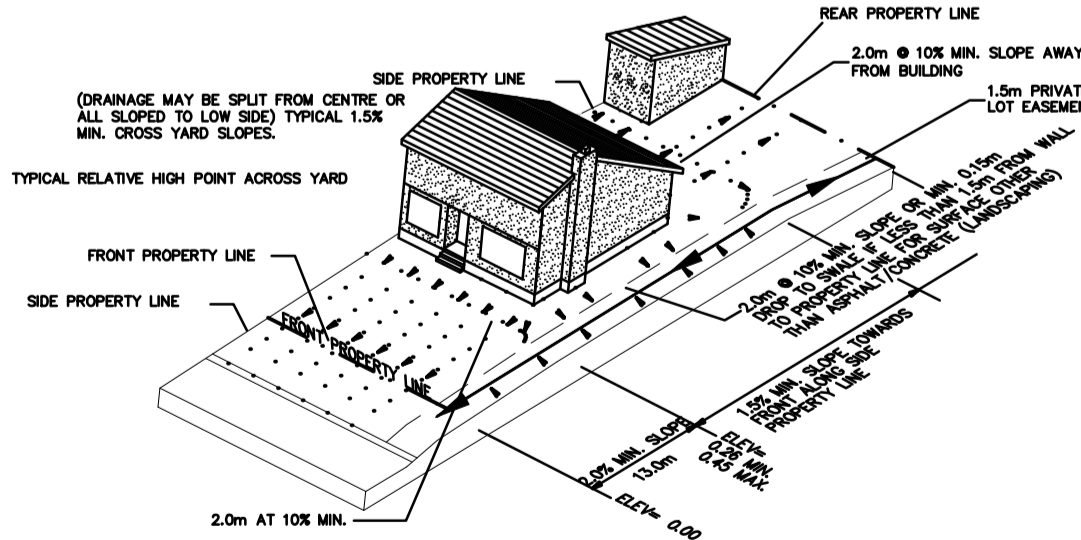

**TYPE D0 - ZERO LOT LINE
STANDARD SPLIT DRAINAGE**
- CONNECT HOUSE ROOF LEADERS TO STORM SERVICES

SWALE DETAIL FOR ZERO LOT LINE GRADING

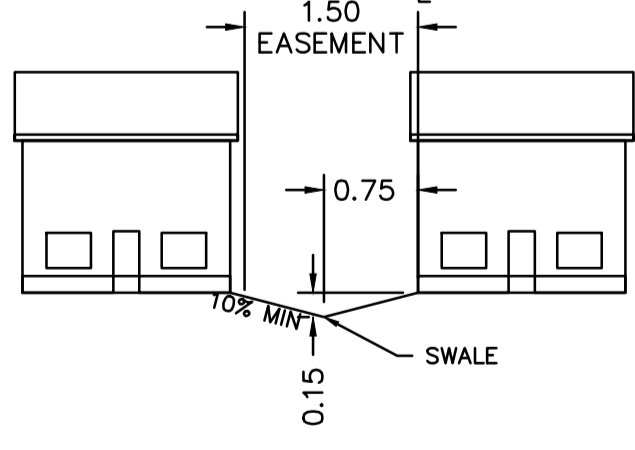

NOTES:
1. SWALE 0.15m DEEP ADJACENT TO BUILDING SWALE DETAIL FOR ZERO LOT LINE GRADING



LEGEND		PROPOSED	EXISTING	FUTURE
---	BOUNDARY OF DEVELOPMENT (STAGE 6)	---	---	---
←	MAJOR DRAINAGE FLOW	←	←	←
1.27%	DIRECTION OF STREET DRAINAGE	←	←	←
649.203	DIRECTION OF LOT DRAINAGE	←	←	←
649.203	L.O.G. ELEVATION	649.203	683.160	683.160
681.60	LOT CORNER ELEVATION	681.60	681.60	681.60
688.82	LOT ELEVATION AS PER LOT GRADING TYPE	688.82	681.60 DITCH	681.60 DITCH
689.50	CENTERLINE SWALE ELEVATION	689.50	689.50	17
689.50	EXISTING CENTERLINE OF DITCH ELEVATION	689.50	689.50	689.50
18	LOT NO.	18	17	17
(A)	LOT GRADING TYPE	(A)	(A)	(A)
(B)	TRANSITION LOT	(B)	(B)	(B)
---	PROPERTY LINE	---	---	---
△	MAJOR STORM PONDING	△	△	△
679.0	EXISTING GROUND CONTOURS	679.0	679.0	679.0

- NOTES:**
- BACKWATER PREVENTION DEVICES SHALL BE INSTALLED ON ALL SANITARY SERVICES.
 - MINIMUM DEPTH OF SERVICE INVERTS IS TO BE 2.74m BELOW ELEVATION AT PROPERTY LINE.
 - THE MANAGER OF THE DRAINAGE SERVICES SHALL HAVE THE AUTHORITY TO APPROVE MINOR CHANGES TO THE LOT GRADING PLAN.
 - IT SHALL BE IN THE SOLE DISCRETION OF THE MANAGER OF THE DRAINAGE SERVICES AS TO WHAT CONSTITUTES A MINOR CHANGE.
 - A CERTIFIED GEOTECHNICAL ENGINEER TO REVIEW FILL CONDITIONS ON EACH LOT PRIOR TO FOUNDATION CONSTRUCTION.
 - LOT GRADING ELEVATIONS SHOULD BE CONFIRMED RELATIVE TO EXISTING BOUNDARY CONDITIONS FOR EACH LOT. ROUGH GRADING TOLERANCE LEVELS SHALL BE MET.
 - A BEARING CERTIFICATE IS REQUIRED ON ALL LOTS WITH 1.5m OR GREATER FILL.
 - ALL ELEVATIONS & DIMENSIONS ARE IN METERS (m) UNLESS NOTED OTHERWISE.
 - OVERALL GRADING & MAJOR FLOW ROUTES NEED TO BE MAINTAINED DURING AND AFTER CONSTRUCTION.
 - ALL LOT DRAINAGE TO BE SELF CONTAINED.
 - BUILDERS/HOMEOWNERS ARE REQUIRED TO CONNECT THE FOUNDATION DRAIN (WITH OR WITHOUT SUMP PUMP) ON ALL LOTS TO THE FOUNDATION DRAIN SERVICE ACCORDING TO CITY OF EDMONTON FOUNDATION DRAIN DISCHARGE COLLECTION SYSTEM GUIDELINES, NOV 2005. PROPOSED SANITARY, STORM & WATER SERVICES.
 - ROOF LEADERS ARE TO DISCHARGE TO SPLASH PADS (SEE SHEET 9 FOR SPLASH PAD DETAIL). CONNECT HOUSE ROOF LEADERS TO STORM SERVICE FOR LOTS 41-70 BLOCK 18, LOTS 10-24 BLOCK 16, LOTS 1-12 BLOCK 19, LOTS 16-27 BLOCK 13, AND LOTS 3-15 BLOCK 14.

GRADING NOTE:
DRAINAGE SERVICES REVIEW AND APPROVAL OF THE LOT GRADING PLAN RELATES EXCLUSIVELY TO THE SURFACE DRAINAGE DESIGN, AND DOES NOT ADDRESS REQUIREMENTS FOR BUILDING FOUNDATIONS OR ANY OTHER USE OF THE LANDS, AND DOES NOT IMPLY THE SUITABILITY OF THE GROUND OR FILLS FOR ANY FOUNDATION REQUIREMENTS OR OTHER USE. IT IS THE OWNER OR THE BUILDER'S RESPONSIBILITY TO EMPLOY THE SERVICES OF A QUALIFIED GEOTECHNICAL CONSULTANT TO DETERMINE GROUND AND SUBSURFACE CONDITIONS THAT MAY AFFECT FOUNDATION DESIGN OR OTHER USE REQUIREMENTS.

- NOTE:**
- FOR ALL ZERO LOT LINE LOTS, LOTS 41-70, BLOCK 18, LOTS 10-24, BLOCK 16: ALL ROOF LEADERS FROM THE DWELLING ARE TO BE CONNECTED TO THE STORM SEWER SERVICE.
 - ALL ROOF LEADERS FROM ACCESSORY BUILDINGS ARE TO BE CONNECTED TO THE STORM SEWER SERVICE OR DIRECTED TO DRAIN DIRECTLY TO AN ADJACENT LANE.
 - NO ROOF LEADERS SHALL BE DIRECTED TO THE MAINTENANCE EASEMENT; AND THE OWNER OF THE ADJACENT SITE IS TO REGISTER AGAINST TITLE, AT THE TIME OF SUBDIVISION, A PRIVATE MAINTENANCE/DRAINAGE EASEMENT A MINIMUM OF 1.5m WIDE

2014-11-04
 C:\CAD\Drawings\DRAWING SET\09A-5311052 STAGE6-C1-06A LOTGR2-RED-20141119.dwg
 C:\CAD\Drawings\DRAWING SET\09A-5311052 STAGE6-C1-06A LOTGR2-RED-20141119.dwg
 Becker Stage 6
 5311052061
 5311052061

ISSUE DATES		REVISIONS		CONSTRUCTION RECORD		CITY OF EDMONTON APPROVED	
DATE	DESCRIPTION	BY	NO.	DATE	DESCRIPTION	APPROVED BY:	DATE
2014/01/24	PRELIMINARY	S.R.	A	2014/03/21	REVISED AS PER CITY COMMENTS	S.R.	2014/06/16
2014/03/21	FOR APPROVAL	S.R.	1	2014/11/20	REDLINE REVISED LOTS GRADES	E.Z.	
2014/06/02	FOR CONSTRUCTION (WATER AND SEWER ONLY)	J.H.					
	AS-BUILT						

CONTRACTOR	STARTED	COMPLETED	SURVEYOR	INSPECTOR	INITIALS	CCC DATE

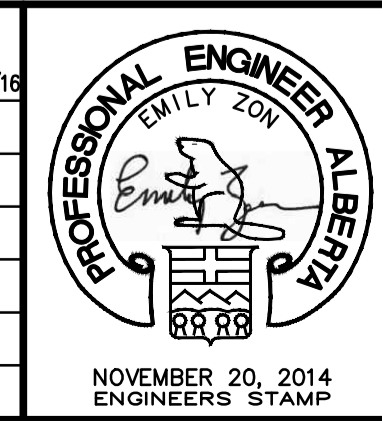

SCALE:	HORIZ.:	1:500	VERT.:
DESIGNED BY:	E.Z.	DATE:	JAN/14
DRAWN BY:	R.S./S.M./H.B.	DATE:	JAN/14
CHECKED BY:	S.R.	DATE:	JAN/14
APPROVED BY:	S.R.	DATE:	JAN/14
PERMITS/APPROVALS		DATE	

PERMIT TO PRACTICE
MMM GROUP LIMITED
 Signature: [Signature]
 Date: NOVEMBER 20, 2014
PERMIT NUMBER: P 8845
 The Association of Professional Engineers, Geologists and Geophysicists of Alberta
 PERMIT TO PRACTICE

THE CITY OF EDMONTON
 CB DEVELOPMENTS LTD

CY BECKER STAGE 6		ZERO LOT LINE GRADING PLAN	
PROJECT NO.	5311052-061	REVISION	SHEET
DRAWING NO.	C1-06A	A1	09A

