

The City of Edmonton
Municipal Cemeteries Facility
Policies, Procedures & Information Guide

Effective Jan 1, 2008
Revised Feb 8, 2016

TABLE OF CONTENTS

Definitions	3
General Information and Regulations	8
- Cemetery Locations	8
- Governing Rules and Legislation	8
- Safety Concerns – Industry Partners & Contractors	9
- Interment Rights	9
- Monuments, Vandalism and Damages	9
- Cancellation/Refund Policy	10
- Refunds	10
- Refunds for Monuments	10
- Burial & Plot Information	10
- Outstanding Financial Commitment	10
- Ownership Transfers	12
- Disinterment Policy & Procedures	14
- Earth Burial Options	16
- Cremation Plots	17
- Cemeteries Position on Scattering	20
- Concrete Liners and Vaults	20
- Pall Bearing Services	22
- Adornment and Floral Tributes	24
- Flowerbeds	26
- Vase Guidelines	27
- Edmonton Cemetery – Cathedral of Memories	28
- Mount Pleasant Cemetery – Indoor Niche Building	28
Monument Information & Regulations	31
- Fees	32
- Delivery and Installation	32
- Delivery Dates and Times	32
- Maintenance, Removal & Replacement	33
- Monuments Materials	33
- Accessories	34
- Inscriptions and Casting	35
- Pre- need monuments and Added Inscriptions	35
- Table 1 – Upright Monument Specifications	36
- Table 2 – Pillow Monument Specifications	37
- Table 3 – Flat Monument Specifications	38
- Table 4 – Military Monument Specifications	41

Definitions

“Base” The lowest portion of a memorial upon which a monument or marker is installed. Dimensions: Length (horizontal) x Width (depth) x Height (thickness).

“Bench” A Commemorative style monument that can be made of granite with engraving or iron/oak with a bronze plaque dedicated to an individual(s). Due to perpetual care, wooden benches are no longer approved to be placed in City Cemeteries.

“Bronze on Granite” Is a marker that has a bronze plaque mounted on a granite base. It can be either a flat marker encased in concrete at ground level or placed on a foundation as an upright.

“Bronze on Granite Section”: A part of the cemetery designated for Bronze on Granite style markers only.

These currently include:

Northern Lights Cemetery: **Grandin Section**

Mount Pleasant Cemetery: **Estate Section**

South Haven Cemetery: **Autumn Glory Section**

“Burial Permit” A burial permit is a document required to bury or cremate the remains of the deceased. It is required by law that cemeteries not perform a burial without a burial permit. If the deceased has been cremated a Cremation Certificate can be accepted in its place.

“Columbarium” Shall mean an above-ground structure designed for the purpose of interring cremated human remains in niches

“Commemorative Monuments”: A monument/plaque etc. that is placed in memory of a person who is interred elsewhere.

“Concrete Liner” or “Vault” – a concrete liner/ or a vault is mandatory for earth burials of traditional casket interments in the City of Edmonton.

A Concrete Liner - The liner is installed for the purpose of cemetery maintenance and safety. Use of a liner ensures burial sections are level; allowing cemetery visitors, workers and equipment to pass over existing graves safely and to facilitate grounds care functions. A concrete liner does not seal and will not prevent the

entrance of water and other gravesite elements into the space occupied by the interred decedent.

A Vault - While a protective vault serves the same functional purpose as the concrete liner it also provides added protection for the interred decedent. The heavier, reinforced construction of a protective vault provides added protection against the weight of the earth above and surrounding the vault. In addition to improved structural strength the protective vault has a sealing lid and high impact ABS lining that combine to seal the vault and protect the interred casket and decedent from the entrance of water and other gravesite elements.

“Cremation Certificate” A certificate produced by a crematorium after a cremation is completed. A cemetery can accept the Cremation Certificate in place of the Burial Permit for cremated remains.

“Cremated Remains” or “Cremains” – human remains that have undergone the cremation process and the body has been reduced to small pieces of ash and bone.

“Crypt” – a burial chamber located within a mausoleum for above ground casket interments. The chamber may contain room for one or two caskets.

“Crypt Cover” – the front facing side of the crypt where the engraving or bronze plaque is attached.

“Death Certificate” A Death Certificate is issued by the Province of Alberta – and it is not required for cemetery services.

“Die” the upper portion of a memorial above the base.

“Disinterment Permit”- a required permit issued by the Province of Alberta permitting the removal and relocation of human remains in cemeteries.

“Field of Honour” Is a designated section in a cemetery which is specifically dedicated to our war veterans.

“Flat (Grass) Marker” A memorial that lies in the ground, flush with the ground level. Dimensions: Length (horizontal) x Width x Height (thickness). These markers will be encased in a concrete foundation.
* Note: A flat marker may be considered an upright marker if it placed on a base on top of a foundation.

“Flat Section” A part of a cemetery where Flat style markers are permitted. No exceptions.

“Foot Marker” or “Flat at Foot” A flat marker that is installed at the foot of a full-size grave. The marker may be made of bronze or granite. Vases are not permitted on markers located at the foot of the grave. Order and installation of a foot marker is only permitted after a marker at head of grave has been installed.

“Foundation” The concrete pad supplied and installed by cemetery staff on which the base of a monument is installed; the concrete or granite frame supplied and installed by cemetery staff that encases a flat marker.

“A Grant of Administration” is a court document which identifies and appoints an individual to act as a representative for a deceased person who did not have a Last Will and Testament.

“Grade beam ” Is a permanent foundation at the head of a row of graves which allows for placement of approved markers throughout the year.

“Granite”- An accepted industry term, granite refers to a range of rocks that are hard, can take a polish but are not technically granite in geological terms. Contact the Municipal Cemetery Office for additional information on acceptable materials.

“Letter of Probate” is a court document which validates the Last Will and Testament of the deceased.

“Memorial” A monument or marker placed upon a cemetery plot for the purpose of identification or in memory of a deceased person or persons.

“Monument Application” Is an application from a monument dealer to the cemetery requesting authorization to produce and deliver a monument for a specific cemetery plot/location. The application includes the specifications of the monument including but not limited to:

- Cemetery Location
- Type of Monument i.e. Upright, flat etc.
- Dimensions and material description of Base, Die, vases and/or accessories

Approval of verified plot owner / signature and legible personal information

“Mausoleum” A free-standing building constructed as a monument enclosing the interment space or burial chamber of a deceased person or persons. The Edmonton Cemetery Mausoleum is a combination of crypts and niches.

“Niches” Shall mean a hollow space in a Columbarium to place cremated remains.

“Niche Cover” The monument front on an individual niche in a columbarium structure. The memorialization is either engraved directly on the granite or marble OR a bronze plaque or wreath is affixed to it.

“Pillar” A Commemorative style monument that is made of granite with a bronze plaque dedicated to an individual(s).

“Pillow Monument” A low, tilted memorial that is taller in the back and gently slopes to the front. Pillow monuments are considered to be upright monuments. Dimensions: Length (horizontal) x Width x Height (back/front). This monument style does not include structures that contain cremated remains.

“Rock-pitched” The exposed edge of a marker which has a rough edge. Minimum thickness 3”

“Sawn sides” The exposed edge of a marker which has a smooth edge. Minimum thickness 4”

“Scattering” respectfully dispersing the cremated of remains of an individual in a designated scattering garden within a cemetery.

“Sloped Upright Monument” (Hickey) A monument that gently slopes downward from the top and is thicker at the bottom. Dimensions: Length (horizontal) x Top Thickness (depth)/Bottom Thickness (depth) x Height (vertical). This monument style does not include structures that contain cremated remains.

“Temporary Marker” A marker generally supplied by funeral homes, made of either plastic or metal and staked into the ground for an allowable period of six months.

“Upright Monument” A memorial that is perpendicular to the ground. Dimensions: Length (horizontal) x Thickness (depth) x Height (vertical). A flat marker with a base is considered an upright/pillow marker. This monument style does not include structures that contain cremated remains.

“Upright Section” A part of the Cemetery that has been designated for upright style markers.

- If an Upright Section has grade beams installed it is restricted to Upright monuments only.
- If an Upright Section (in a Historic Cemetery) has no grade beams installed a flat marker may be permitted. Please confirm with Cemetery Administration Office for confirmation.

General Information and Regulations

Cemetery Locations

The City of Edmonton has seven active municipal cemeteries, including three that are designated as historical. These regulations broadly address all of these cemeteries and it is recommended that the Municipal Cemetery Office be consulted and written permission obtained for any exceptions that fall outside the regulations.

Historical Cemeteries

Beechmount Cemetery

(Admin Office)
12420-104 St.
780 442 0974

Mount Pleasant Cemetery

5420-106 St.

Edmonton Cemetery

11820-107 Ave.

Neighbourhood Cemeteries

South Haven Cemetery

5004 Meridian St.

Northern Lights Cemetery

15203 Campbell Road

Little Mountain Cemetery

16025-54St.

Clover Bar

2025 Yellowhead Trail N.E.

Rules for Cemetery Visitors

In order to promote the safe, enjoyable and reasonable use of cemetery facilities and to protect and preserve natural ecosystems for the benefit of all citizens of the City, visitor conduct and activities are subject to City of Edmonton Bylaw 2202 (Parkland Bylaw). The following is a list of the legislation (but not limited to) that governs cemeteries in Alberta.

Alberta Cemeteries Act

Freedom of Information and Privacy Act

Wills and Inheritance Legislation

Veterans Affairs Act

Municipal Government Act

Alberta Water Act

Burial of the Dead Act

Occupational Health & Safety Act

Environmental Protection Act

Specific to City of Edmonton Cemeteries

Parkland Bylaw 2202

Administration (City Administration) Bylaw 12005

Municipal Cemeteries Facility - Policies, Procedures & Information Guide

Safety Concerns - Industry Partners & Contractors

Funeral Homes, Monument Dealers and sub-contractors of both these industry partners are required to maintain their own Workplace Health & Safety Program that is in compliance with the current *OH&S Legislation*. It is recommended that it include the possible hazards that may be encountered when carrying out the duties to which they are assigned within City Cemeteries.

To assist the City Cemetery Staff in maintaining a safe working environment for it's employee's and industry partner representative's it is imperative that all work being completed in any city cemetery site first be scheduled and approved by the operations staff supervisors. Interments are the exception as they are scheduled a minimum 48 business hours in advance with the Administration office.

The following monument related items require pre-approval.

- Monument Applications/Orders
- Monument Deliveries
- Additional Inscriptions Completion

Interment Rights

- A sale of a "plot, niche, crypt or other interment location" can be viewed as a long term lease. The land ownership is retained by the Cemetery and the rights of interment are purchased in a sale.
- The legal owner has the only authority over the authorizations for interments and monuments being requested for the interment location.

Monuments & Vandalism

- The plot owner is responsible for the proper condition and replacement of a memorial and the City assumes no liability or responsibility for loss or damage to any memorials through acts of vandalism or natural erosion.
- The City may remove a damaged memorial.
- The City repairs and replaces existing memorial foundations if necessary due to maintenance and safety concerns as determined by cemetery staff at no charge to the plot owner.

Cancellation / Refund Policy

As per the *Alberta Cemeteries Act*:

- Cancellation of a contract can be requested at any time for any reason. You may cancel without charge or penalty at any time during the period from the day you enter into the contract until 30 days after you receive a copy of the contract. If you cancel after 30 days you may still have to pay for interment space and for any cemetery supplies and cemetery services that have already been supplied, performed or delivered, as the case may be.

- To cancel, you must give a notice of cancellation to the owner of the cemetery, columbarium or mausoleum at the address shown in the contract or to the seller of this contract at the address shown in the contract. You should give notice of cancellation by a method that will allow you to prove that you gave notice, such as registered mail, fax, and courier or by personal delivery.

- **Refunds** – The City of Edmonton does not allow the resell of interment space on the open market. As a seller who does not allow the resale of plots on the open market it is legislated that the City must buy back the unused interment space and unused services. If the cancellation is requested during the 30 day cancellation period, then a full refund will be issued. Once this period is over, a refund of at least 85% of its market value of the interment space at the date of resale. Additional fees may apply dependent upon the circumstances of the original sale and products already provided.

- **Refunds for Monuments** –If the cancellation is requested during the 30 day cancellation period, then a full refund will be issued. Additional fees may apply dependent upon the circumstances of the original sale and products already provided.

- If a monument is ordered with the signed approval of the purchaser before the 30 day cancellation period is over then a waiver must be signed by the purchaser to waive the 30 day waiting period and cancellation rights.

Burial & Plot Information

- Burial information will be provided upon request to memorial dealers or owners/families. It is the responsibility of the memorial provider to meet with plot owners/families on-site at the cemetery to verify the accuracy of burial location particulars (including plot ownership, left/right memorial placement).

- The Municipal Cemetery Office only provides details about the most recent grave or plot ownership located in its files for the purposes of finding a grave or plot for interment, monuments or marker placement.

Outstanding Financial Commitment

- In default of outstanding financial commitment, monument installation may be denied and memorials removed if outstanding debt exists on plot, services provided, and memorial and/or installation costs

Ownership Transfers

○ **Plot owner to spouse/family member**

In order to transfer ownership of a plot that is held in one spouse's name to the other spouse a Transfer request must be completed, the owner must provide proof of identity either in person with government issued identification and/or by swearing a statutory declaration of intent with a Commissioner for Oaths. The administration fee in effect at the time will be applicable for each plot being transferred.

○ **Multiple plot ownership- separation of ownership**

When a plot has multiple owners identified and one owner wishes to transfer full rights to the other owner, the person transferring the ownership will complete the Transfer request (see form in Appendix) and provide proof of identity either in person with government issued identification or by swearing a statutory declaration of intent with a Commissioner for Oaths. The administration fee in effect at the time will be applicable.

○ **Plot Owner, AB Health Services and/or AISH (Formerly AB Social Services & AISH)**

Plots (interment rights) purchased and paid for by AB Health Services for deceased persons who qualified for assistance are considered "owned" by AB Health Services. The arrangement for the purchase is limited to the interment rights for a six foot burial or a cremation burial, which is utilized by the qualifying deceased person.

Further burials in the plot will require "permission" to transfer the ownership of the plot to a new owner from AB Health Services. As the original contract is for the initial burial, transferring the ownership of the plot does not allow for additional burial space (interment rights). To allow for additional burial space the purchase of these interment rights will be 50% of the current market value. Additional fees including but not limited to: Plot transfer fee, Open/Close, Concrete Liners and/or overtime charges may also apply.

The City of Edmonton cemeteries **will not** pursue permission for interested parties with AB Health Services. It is the responsibility of the individual to obtain the required authorization and provide it to the cemetery before any transaction can occur.

- **Plot owner to interested purchaser**

As the City of Edmonton does not allow private sale of cemetery plots on the open market, a cancellation of the existing contract and a refund to the plot owner would be processed and a new contract with the interested purchaser would be required.

- **Upon death of Plot owner by Executor**

At the request of the executor/executrix the ownership will be transferred to the designated beneficiary for no charge when the interment arrangements are being finalized. A transfer form and a copy of the will and proof of identity are required from the executor/executrix before the transfer can be completed.

- **Plot owner deceased, estate settled**

If the owner on record is deceased it is necessary to confirm that the appropriate beneficiary is identified before any ownership transfers, interments or monuments can be completed for any location. As this type of determination is beyond the scope of the authority of any cemetery and is determined by Wills and Inheritance Laws the following legal documentation is required to confirm the appropriate beneficiary.

The *Letter of Probate* for the estate of the plot owner on record. This will identify the Executor. This person will be required to provide proof of identity.

OR A *Grant of Administration* for the estate of the plot owner on record. This will detail the personal representative for the deceased in the absence of a Will. This person will be required to provide proof of identity.

OR A *Court Order* directing that a certain individual has been declared the beneficial owner of the deceased assets. This person will be required to provide proof of identity.

Once the proper documentation is obtained a transfer of the plots to the new owners name can be completed at the Cemetery Administration Office. Please be aware that there is a transfer fee for each plot location.

Disinterment Policy and Procedures

(as per Government of Alberta Web-site /www.servicealberta.gov.ab.ca)

Disinterment of Casket Burial

Disinter/reinter permits (current year) are required to disinter or remove the remains of a deceased person from their place of interment, usually for the purpose of cremation or burial in a new location.

A cemetery will not consent to the opening of a grave site and/or removal of a body without a disinter/reinter permit from Vital Statistics.

As some viruses and diseases may remain in an active state for decades after the death of an individual, Vital Statistics will review all applications and the cause of death to ensure that restrictions are closely followed.

Making an Application to the Province for the Disinterment Permit

The applicant must be an adult next-of-kin as defined by the Fatality Inquiries Act. Where a next-of-kin is not available, the application may be made by another person along with a written explanation of the circumstances.

When making an application to Vital Statistics directly, the following particulars are required:

- Full name of the person making the application
- The relationship between the person making the application and the deceased person
- Full return address and telephone number of the applicant
- Signature of the person making the application
- Date the application is being made
- Last name of the deceased
- Given names of the deceased, including the first and middle names (all given names must be shown)
- Gender, indicate either male or female
- Date of death
- Place of death (indicate the city, town or village in Alberta where the death occurred)
- Where the deceased is currently buried
- Where the deceased is to be reinterred

- Reason for request
- Upon approval of the application, where should the permit be mailed

Disinterment of a body shall not take place until an Application for Disinterment in the prescribed form, together with the Certificate of Death showing the cause of death, is given to the Director of Vital Statistics. Forms may be obtained from the Funeral Homes or the Vital Statistics office. When the death occurred in Alberta, Vital Statistics will most often have the cause of death on record.

When the death occurred outside Alberta, it is the responsibility of the applicant to obtain the Medical Certificate of Death (cause of death) from the appropriate jurisdiction.

Application to Cemetery to Perform Disinterment

When permission has been obtained from the Province to perform the disinterment, an application and payment to the cemetery is also required before the disinterment can occur. Please contact the cemetery office or a funeral home for detailed instructions.

Disinterment of Cremated Remains

Although a disinterment permit is not required from the Provincial Government in relation to cremated remains, a cemetery application and fee are still required.

In order to maintain accurate burial records and comply with the *Alberta Cemeteries Act* & the *City of Edmonton Parkland Bylaw* it is essential that the information captured by the application and the removal of the remains be completed by City of Edmonton Cemeteries Staff.

The removal of any remains without the proper authority can result in legal action.

Earth Burials Options

The City of Edmonton Municipal Cemeteries has criteria for the interment of human remains, including standards for depth of burial and size of casket or grave liner per each 4 x 9' plot. The following are minimum standards, and it is recommended that the Municipal Cemetery Office be contacted for additional details concerning grave and cremation burials.

Full-Sized Plots

For interment of human remains in a 4 x 9' full size plot:

- The depth of the grave must be sufficient to allow for a minimum of 3' of earth between the upper surface of the grave liner and the level of the ground.
- The casket and grave liner or vault must be no greater than 42" in width and 8' in length.

Possible Arrangements in Full Casket Plot

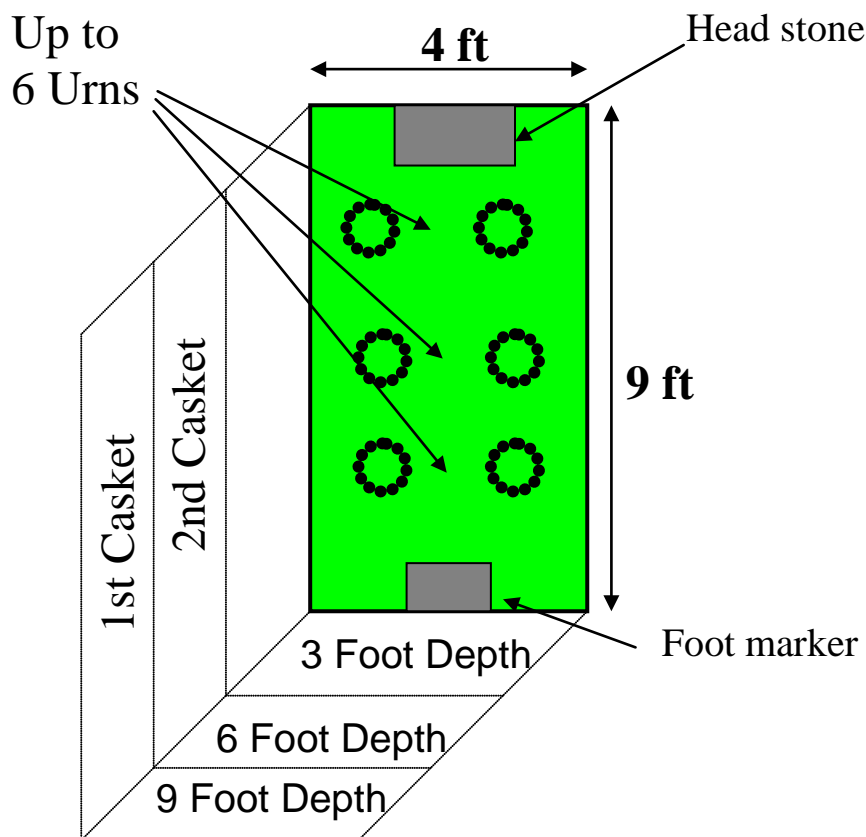

Child Size Plots

For interment of human remains in a 4' x 6' child size plot:

- The depth of the grave must be sufficient to allow for a minimum of 3' of earth between the upper surface of the grave liner and the level of the ground.
- The casket and grave liner or vault must be no greater than 24 in width and 60 in length.
- The Child Sized Plots are in designated areas and may hold a maximum of 2 traditional child burials (one at 9 feet and one at 6 feet) with a maximum of 2 urns allowed per plot at the 3 foot depth. The cremated remains are limited to immediate family only. (mother, father, sister, brother)

Possible Arrangements in Child Casket Plot

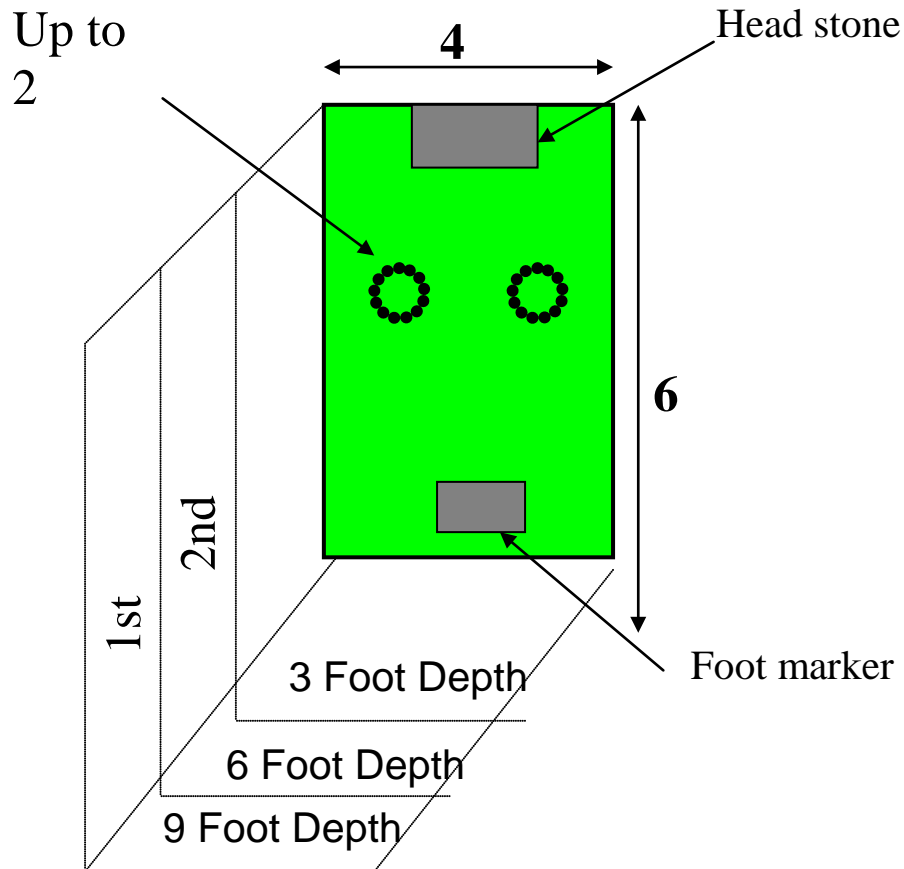

Cremation Plots

For interment of cremated remains in a 4' x 9' full size cremation plot:

- A maximum of six urns per plot.

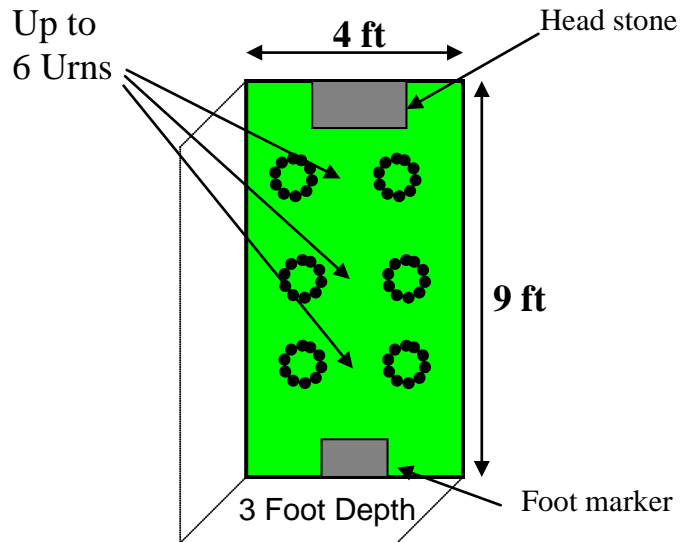

For interment of cremated remains in a 3' x 3' cremation plot:

- A maximum of two urns is per plot.

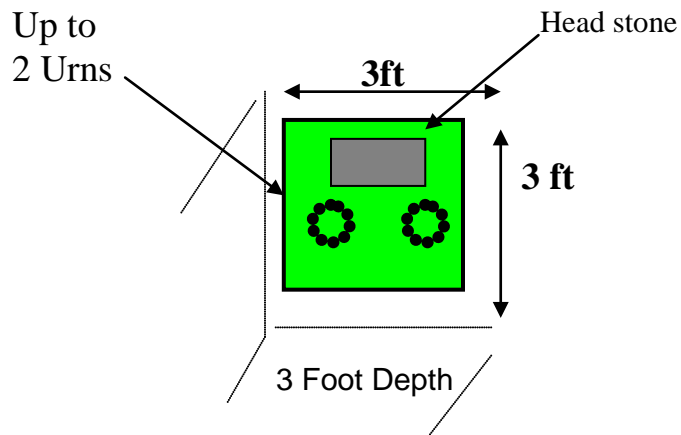

For interment of cremated remains in a 4' x 3' cremation plot:

- A maximum of two urns is per plot.

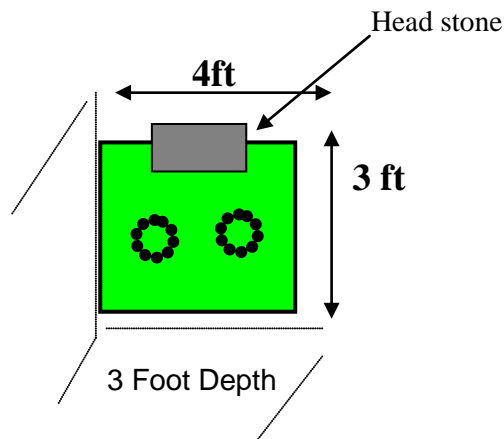

- The exception being in Mount Pleasant where 3 urns are allowed in specific locations. Locations need to be confirmed by cemetery administration staff.

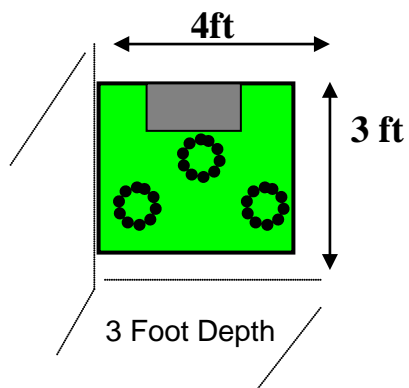

For interment of cremated remains in a 2' x 2' cremation plot:

- A maximum of one urn per plot. (Beechmount Location)
- Memorialization on Memorial Wall (Beechmount Location)

Memorialization on Memorial Wall
Beechmount Only

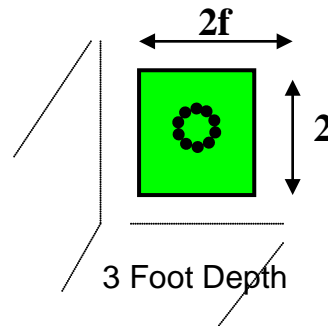

Scattering of cremated remains:

- Scattering of cremated remains is only permitted within designated areas and must be supervised and/or carried out by cemetery staff.

Municipal Cemeteries Position on Scattering

The City of Edmonton does permit the scattering of ashes in specifically allocated areas of the Municipal Cemeteries only. Beechmount, Mount Pleasant, Northern Lights, and South Haven Cemetery all have specific scattering areas. Because of the permanency of scattering, the Municipal Cemeteries strongly recommends that the decision to have remains scattered be thoroughly be discussed and thought through in advance.

Concrete Liners or Vault

It is a mandatory requirement for all full casket burials that either a concrete liner (purchased through the City of Edmonton) or a vault (supplied through the funeral home) are used to house the casket when placed in a grave. This requirement assists in the operational needs of the cemetery now and into the future by reducing any safety concerns caused by collapsing ground areas and reduces the amount of long term care required in the cemetery overall.

Pall bearing Services

For traditional casket burials, it is expected that the funeral home, family or friends provide (6) six pallbearers for the cemetery service.

Our workplace safety regulations require that for all instances of pall-bearing that a total of six pall-bearers are required. This means that even when booking pall-bearing services from the cemetery it is expected and required that the Funeral Homes will coordinate and ensure that there are a minimum of four other pall-bearers (i.e. could be a combination of Funeral Home Staff and family) in addition to our two cemetery staff.

In the event that the full complement of (6) six pall bearers is not present, the service will be delayed until the full complement is arranged by the family or the funeral home. Additional fees will be levied if the service is delayed beyond the allocated time for the interment.

Normally because we are involved in providing multiple services at various cemetery locations on any given day, we can only provide a maximum of two staff at any one given time to assist with pall-bearing.

Adornment

Plots may not be adorned except for memorials as permitted and outlined in these regulations.

Floral Tributes

Flowers and flowerbeds are subject to environmental factors and inadvertent maintenance damage. The City assumes no responsibility for loss or damage to floral tributes placed on graves and assumes no responsibility for their care.

Live flowers placed on a grave at the time of interment will be left for a minimum of one week depending upon environmental conditions.

Flowerbeds are not permitted in the Field of Honour.

Flowerbeds may be planted along the front edge of a memorial to a maximum depth of 15". Only annual flowers are permitted and may be planted and from April 1 to September 30.

Artificial flowers are permitted in approved vases and may remain throughout the year. If the flowers are unsightly or weathered they may be removed at the cemeteries discretion.

Artificial floral arrangements not in vases and wreaths may be placed on a grave between October 1 and the start of cemetery grounds cleanup the following spring, at which time any remaining artificial floral tributes will be removed and discarded. Environmental and site conditions may alter the placement or location of any such arrangements.

Adornment and Floral Tributes for Niches

Indoor Niches - Approved memorial display items may be placed inside the niche at the time of interment or at the request of the owner once per year at no charge during regular business hours. The year will be defined as January to December. Each additional request during the calendar year will be subject to the regular open/close fee and after-hour fees (if applicable) in effect at the time. Arrangements must be made a minimum of 48 hours in advance by calling the Cemetery Administration Office.

Approved Item Criteria for Indoor and Outdoor Niches

1. The item is not subject to decomposition.
2. The item is not deemed offensive. (As determined by the Cemetery Administration Office)
3. The item does not pose a potential safety hazard.
4. **No candles of any type are permitted.**

Glass Front Niches – all items will be placed inside the niche. Items affixed to the outside of the glass or left on the floor will be removed without notice. Any damages caused to the niche front due to prohibited materials will be the financial responsibility of the niche owner.

Marble or Granite Front Niches – The following items may be purchased from the Municipal Cemetery Office for adornment of marble or granite niches. As other suppliers may not offer the same products, only items pre-approved and sold by the Municipal Cemetery Office will be permitted.

- Bronze plaques (if applicable)
- Engraving (if applicable)
- Commemorative ceramic photographs (Outdoor Niches Only)

These items will require an application and installation shall be completed by cemetery staff.

Items affixed to the outside of the niche or left on the floor will be removed without notice. Any damages caused to the niche front due to prohibited materials will be the financial responsibility of the owner.

Floral Tributes for Niches

Indoor Niches – Glass Front

Silk/artificial flowers are permitted inside the niche

Indoor Niches – Marble Front

Bronze plaques that are cast with flower holders may contain silk or artificial flowers.

Families are responsible for maintaining the appearance of silk flower arrangements. Cemetery staff, without prior notice, will remove silk flower arrangements that are not adequately maintained.

Outdoor Niches

Bronze plaques that are cast with flower holders may contain silk or artificial flowers.

It is recommended that niche owners include the niche monument under their Homeowner or tenant insurance. The City of Edmonton is not responsible for damages caused to the vases or niche cover due to vandalism.

Other than at the time of a funeral, fresh flowers may not be left on the ground, floor or ledges. Cemetery staff will remove and dispose of prohibited flowers, plants or other objects without prior notice.

Adornment and Floral Tributes for Earth Burials, Scattering Gardens, Memorial Benches and Memorial Pillars

The City of Edmonton considers all City Cemeteries to be Parkland. Thus all the regulations identified under the Parkland Bylaw 2202 are in effect. Adornment is limited to approved monuments and vases, floral tributes and flowerbed services.

It is **highly recommended** that items of a personal nature not be left at gravesites as the cemetery is considered a public place with unrestricted public access.

Disposition of items collected by the City Cemeteries staff will be handled in the following manner.

1. Items that are subject to decomposition will be disposed of immediately. This includes food items, stuffed animals etc.
2. Items that do not decompose will be removed without notice and held for a minimum of one month. After a month has passed the items will be disposed of.
3. To find an item that may have been removed by Cemetery Staff please check the shelving units located in the cemetery in question.

Beechmount Cemetery – behind the little house

Mount Pleasant Cemetery – in front and to the north of the Indoor Niche Building

Edmonton Cemetery – west side of mausoleum (exterior)

Northern Lights Cemetery- east of the operations shop

South Haven Cemetery – on west side of operations yard

Little Mountain Cemetery call Administration Office – 780 442-0974

Cloverbar Cemetery – call Administration Office – 780 442-0974

Floral Tributes for Earth Burials

At time of an interment – Fresh or artificial flowers placed on a grave at the time of interment will be left for a minimum of one week.

Tributes after the interment – Artificial flowers are permitted in approved vases and may remain throughout the year.

Artificial floral arrangements not in vases and wreaths may be placed on a grave between October 1 and the start of cemetery grounds cleanup the following spring, at which time any remaining artificial floral tributes will be removed and discarded. Environmental and site conditions may alter the placement or location of any such arrangements.

Fresh Floral Tributes in approved vases will be removed once the flowers have perished.

Fresh Floral Tributes placed on the ground or in an inappropriate vase will be removed (including the vase) during regular ground maintenance without notice.

Flowerbeds

- Flowerbeds may be planted along the front edge of a memorial to a maximum depth of 15".
- The flowerbed will be enclosed with approved landscape edging
- Only annual flowers are permitted and may be planted and from April 1 to September 30.
- **Flowerbeds are not permitted in the Field of Honour.**

Flowers and flowerbeds are subject to environmental factors and inadvertent maintenance damage. The City assumes no responsibility for loss or damage to floral tributes placed on graves.

Existing flowerbeds that are not maintained (cleaned and planted) by June 30th of each year may be returned to grass to facilitate maintenance of the cemetery grounds.

Vase Guidelines

Permitted Material Composition

Permanently affixed to or beside marker at HEAD of Grave

- Granite (regular or inverted)
- Bronze (regular or inverted)
- Metal Craft with Coating (regular or inverted)

Temporary Vases with stands or ground spikes

- Plastic
- Metal Style – available at Cemetery Administration Office

Vases are not permitted:

1. In front of a flat marker
2. At the foot of a plot (as part of marker or on it's own)
3. On military memorials
4. In the Field of Honour

Vases have a limited lifespan and are not under warranty by the cemetery. A vase installed in a northern climate is subject to extreme changes in temperature and is accessible to people, wild-life and unforeseen factors that will affect the life of the vase. Depending upon the composition of the vase it should be expected that replacement vases will need to be purchased periodically by the plot owner due to normal wear and tear.

Vases that are broken and considered a maintenance hazard will be removed by the cemetery staff.

EDMONTON MAUSOLEUM CATHEDRAL OF MEMORIES & THE MOUNT PLEASANT INDOOR NICHE REGULATIONS

Use of Crypts (Edmonton Cemetery)/**Niches** (Edmonton & Mount Pleasant)

The purchase of a crypt covers basic inscription, entombment and perpetual care; the purchase of a cremation niche covers basic inscription/bronze plaque/name plate, perpetual light (if available at location), inurnment and perpetual care.

Before the opening of a crypt/niche prior to entombment, the owner or owner's designate must sign an interment authorization form at the Municipal Cemetery Office.

Crypt/niche owners may not sell their crypt/niche in whole or in part to any third party. Should a family no longer require cemetery arrangements, they may return the cemetery space to the City for a refund or exchange to another City of Edmonton Municipal Cemetery location. Transfer of ownership within families is permitted providing the transfer is processed and approved by the Municipal Cemetery Office. An administration fee will apply.

The City assumes no responsibility for damage to mausoleum crypt faces/ niche covers for engraving purposes. The responsibility for replacing any damaged crypt door/ niche cover is the sole responsibility of the owner's family.

Perpetual care funds provide for the ongoing routine maintenance of the facility. The City assumes no responsibility for damage incurred through vandalism or acts outside its control, other than normal wear occurring over time.

Adornment

The following items may be purchased from the Municipal Cemetery Office for adornment of crypts. As other suppliers may not offer the same products, only items pre-approved and sold by the Municipal Cemetery Office will be permitted.

- Perpetual crypt lights
- Commemorative ceramic photographs
- Bronze frames

These items will require an application and installation shall be completed by cemetery staff.

Approved memorial display items may be placed inside the niche at the time of interment or at the request of the owner once per year at no charge. Additional requests an opening/closing fee will apply.

The use of urns composed of organic materials within the Edmonton Mausoleum Cathedral of Memories is restricted to marble front niches only.

The use of urns composed of organic materials within the Mount Pleasant Indoor Niche Building is prohibited.

Photographs and/or other memorabilia may not be taped, glued, or otherwise affixed to a crypt/niche front, or placed on the floor.

Items that are not pre-approved or are prohibited will be removed by cemetery staff without notice.

Any damages caused to the crypt/niche front due to prohibited materials will be the financial responsibility of the owner.

Floral Tributes

Only approved crypt vases and silk flower arrangements are permitted. Approved vases and silk flower options are available for purchase through the Municipal Cemetery Office.

Use of approved silk flower arrangements is limited to one arrangement per crypt/niche.

Families are responsible for maintaining the appearance of silk flower arrangements. Cemetery staff, without prior notice, will remove silk flower arrangements that are not adequately maintained.

Other than at the time of a funeral, fresh flowers may not be left on the floor or ledges. Cemetery staff will remove and dispose of prohibited flowers, plants or other objects without prior notice.

Visitors

The "Facility" will be open to approved family members with access cards/key access for visitation from 8am to 9pm, Monday through Sunday. Visitation will be prohibited outside these hours and the "Facility" security alarm will be armed. The City of Edmonton reserves the right to change family visiting hours without prior notice.

The "Facility" is armed with a security system that will operate outside of approved family visiting hours; however individual niches/crypts are not equipped with individual security contacts.

No candles of any type are permitted.
Only artificial silk flowers are permitted.

MEMORIAL REGULATIONS

The following regulations address general memorial application processes, dimensions, materials, and delivery and installation requirements. Please contact the Municipal Cemetery Office for further specifications and exceptions.

Applications

The Municipal Cemetery Office requires that a Monument Application Form be completed and submitted by the memorial provider for all specific memorial materials and dimensions. Including the corresponding application and monument installation fees This enables cemetery staff to determine whether all requirements are met for all requested memorials, including materials and dimensions, or for proposed work to existing memorials. Application forms are available at the Municipal Cemetery Office.

Written approval will be provided to the memorial provider. Memorials arriving for installation without proper written approval from the Municipal Cemetery Office will be refused and returned to the memorial provider. Approvals are only acceptable in written form. **Verbal inquiries as to the regulations are not considered approvals.** Monuments that are produced without prior cemetery approval are the responsibility of the monument purchaser and the monument provider.

Owing to the special nature of historical cemeteries and necessary on-site inspections, memorial applications for historical cemeteries (Beechmount, Edmonton and Mount Pleasant) may take up to two weeks for processing.

Memorial applications will be marked and returned as “not approved” if:

- Memorials do not meet dimensional and material requirements.
- Are in anyway incomplete.
- Are submitted on an outdated form.
- Payment is not received with application.

NOTE: Although the Municipal Cemetery Office distributes new application forms and regulations as required each year, it is the responsibility of the memorial provider to ensure that the most current form is correctly completed and submitted. Drawings of proposed monuments are not accepted. The City assumes no responsibility for claims or damages resulting from errors in memorial content, layout, formatting or design, including but not limited to errors in wording or name placement, spelling, date or other inaccuracies relating to inscribed information.

1.1. Fees

Please contact the Municipal Cemetery Office for current application, installation and administration fees and payment processes

1.2. Delivery and Installation

All memorial delivery and installation must be accompanied by proper written approval as described above.

Upon delivery:

- Flat Markers: Cemetery staff will inspect and install markers, subject to approval and stated requirements.
- Upright and Pillow Monuments: Memorial providers will install monuments, subject to approval and stated requirements.

Hours and dates for memorial delivery:

- Flat Markers: 8:00 a.m. to 4:00 p.m., Monday to Friday.
 - Flat Markers for Mount Pleasant Cemetery, Clover Bar Cemetery and South Haven Cemetery deliver to South Haven Cemetery
 - Flat Markers for Edmonton Cemetery, Little Mountain Cemetery, Northern Lights Cemetery and Beechmount Cemetery deliver to Beechmount Cemetery
- Upright and Pillow Monuments: Dawn until dusk, seven days per week.

Hours and dates for memorial installation:

- Flat Markers (installed by cemetery staff only): April to October, generally*.
- Upright and Pillow Monuments: Dawn until dusk, seven days per week.

***NOTE:** Beginning October 1, the installation of flat markers is subject to weather conditions; once frost and a layer of snow is on the ground, installation will cease. The Municipal Cemetery Office will not, therefore, guarantee flat marker installation after October 1, and will advise memorial providers by fax when installation has ended for the winter and resumed in the spring.

1.3. Work Notification Sheet

The Municipal Cemetery Office requires that memorial providers submit a work notification sheet following all marker delivery, monument installation or completion of added inscriptions or pick-up and removal of any memorial. The notification sheet must summarize and verify work being carried out in the cemetery. Failure to submit a work notification sheet will result in an administration charge per incident.

1.4. Maintenance, Removal and Replacement

The plot owner is responsible for the proper condition and replacement of a memorial and the City assumes no liability or responsibility for loss or damage to any memorials through acts of vandalism or natural erosion.

The City may remove a damaged memorial.

The City repairs and replaces existing memorial foundations if necessary due to maintenance and safety concerns as determined by cemetery staff at no charge to the plot owner.

Existing monuments that do not meet current specifications will be grandfathered, however, in the event the monument needs replacement, the new monument (s) are required to meet the existing regulations in place at the time of purchase.

1.5. Materials

All memorial materials, including marker bases, must be made of granite* or bronze.

A temporary plastic or metal marker may be approved and left on a grave for a period of six months.

Marble may only be used for repairs to existing marble memorials, not replacement.

***Note:** An accepted industry term, granite refers to a range of rocks that are hard, can take a polish but are not technically granite in geological terms. Contact the Municipal Cemetery Office for additional information on acceptable materials.

Photographic Reproductions

Memorial photographic reproductions are conditionally permitted, depending upon the type of photographic reproduction and style of memorial.

Restrictions are listed below. Please contact the Municipal Cemetery Office for further clarification on what types of photographic reproductions are permitted and on which monument or marker styles.

All photographic reproductions must be recessed on flat markers and not extend higher than the marker profile.

No photographic reproductions are allowed on military memorials.

Photoblcasts are not permitted.

Laser etches are not permitted on flat markers.

NOTE: Photographic reproductions and their replacement are the responsibility of the memorial provider and owner. The Municipal Cemetery Office will redirect the memorial owner to the memorial provider to resolve any concerns over broken, vandalized or stolen reproductions.

1.6. Accessories

Granite balls, pagodas or any other type of approved accessory must:

- Be attached with a minimum ½" diameter pin size that extends a minimum 2" into both the accessory and the die.
- Be attached with permanent adhesive.
- **In combination with the die**, does not exceed the maximum allowable monument height and width.

Vases are not permitted in front of a flat marker or at the foot of a plot.
Vases are not permitted on military memorials or in the Field of Honour.

Inscriptions/Casting

- Can include Names, DOB, DOD and Epitaph.
- The City of Edmonton reserves the right to remove any memorial that can be construed to mean or represent something offensive either in written or pictorial form.
- Trade names and logos are prohibited on all memorials.
- Commemorative/"In Memory" inscriptions when no burial on location exists must state that interment has taken place elsewhere.
- Plot descriptions are permitted on the lower right-hand corner of all memorials at the expense of the memorial owner.

Pre-Need Memorials and Added Inscriptions

All pre-need memorials applications fees can be pre-approved and pre-paid. The additional inscription or additional tabs costs will be determined at the time of need. The Municipal Cemetery Office will return all necessary copies and it is then the responsibility of the memorial provider to resubmit the approved form(s) upon memorial delivery or completion of additional inscription work.

NOTE: Commemorative/"In Memory" inscriptions when no burial on location exists must state that interment has taken place elsewhere.

Additional Monument Information

- The following will be considered on a case by case basis:
 - Statues, cairns and boulders
 - Family memorials
- Due to the nature of the regular cemetery daily operation, the maximum amount of graves a monument may span is two (2). The maximum size allowed for the foundation is 6 inches smaller than the combined widths of the graves.
- Monuments larger than the above requirement exceed the tolerances of the regular independent foundations and grade beams and interfere with the normal cemetery maintenance and operations.
- Existing monuments that do not meet these specifications will be grandfathered, however, in the event the monument needs replacement, the new monument (s) are required to meet the existing regulations in place at the time of purchase.

BM-Beechmount CB-Cloverbar	ED-Edmonton LM-Little Mountain	MP-Mount Pleasant	NL-Northern Lights			SH-South Haven		
	Grave Width	Foundation	Base			Die		
	Size (")	Max. Length (")	Max. Length (")	Max. Height (")	Min. Width (")	Max. Length* (")	Max. Height (")	Min. Thickness **
SINGLE UPRIGHT MONUMENT ON PLOT WITH GRADE BEAM								
Full Size Regular Plots BM, ED, MP, NL, SH, LM, CB	48	42	42	8	8	38	36	4
NL Section C & D Full Size Premium Plots	48	42	Min 38 Max 42	Min 8	Min 8 Max 24	Min 30 Max 38	Min 36 Max 40	Min 8
SINGLE UPRIGHT MONUMENT ON PLOT WITH NO GRADEBEAM INDIVIDUAL FOUNDATION REQUIRED								
Full Size Regular Plots BM, ED, MP, NL, SH, LM, CB	48	42	36	8	8	32	36	4
Child Size Plot BM, ED, MP	36	30	24	8	8	20	20	4
Cremation Plot BM, ED, MP	36	30	24	8	8	20	20	4
DOUBLE UPRIGHT MONUMENT ON PLOT WITH GRADE BEAM								
Full Size Regular Plots BM, MP, NL, SH, LM, CB	96	90	90	8	8	86	36	4
NL Section C & D Full Size Premium Plots	96	90	Min 72 Max 90	Min 8	Min 8 Max 24	Min 60 Max 86	Min 36 Max 40	8
DOUBLE UPRIGHT MONUMENT ON PLOT WITH NO GRADEBEAM INDIVIDUAL FOUNDATION REQUIRED								
Full Size Regular Plots BM, ED, MP, LM, CB	96	90	84	8	8	78	36	4
Child Size Plot BM, ED, MP	72	66	60	8	8	56	20	4
Cremation Plot BM, ED, MP	72	66	60	8	8	56	20	4
Additional Information 1) Maximum Height of Monument includes base height, die height and accessories that are situated at the top of the die (for example a pagoda ball). This combination cannot exceed 48" 2) Minimum thickness is measure at the bottom of the die where it is attached to the base. 3) Due to the nature of the regular cemetery daily operation, the maximum amount of graves a monument may span is two. The maximum size allowed for the foundation is 6 inches smaller than the combined widths of the graves.								

BM-Beechmount Haven CB-Cloverbar	ED-Edmonton	MP-Mount Pleasant	NL-Northern Lights	SH-South				
	LM-Little Mountain							
	Grave Width	Foundation	Base			Die		
	Size (")	Max. Length (")	Max. Length (")	Max. Thickness (")	Max Width (")	Max. Length* (")	Min. Height (")	Max. Width (")
SINGLE PILLOW MONUMENT ON PLOT WITH GRADE BEAM								
Full Size Regular Plots BM, ED, MP, NL, SH, LM, CB	48	42	42	4	18	38	Front 3 Back 5	14
Child Size Plot BM, ED, MP	36	30	30	4	18	26	Front 3 Back 5	14
SINGLE PILLOW MONUMENT ON PLOT WITH NO GRADEBEAM INDIVIDUAL FOUNDATION REQUIRED								
Full Size Regular Plots BM, ED, MP, NL, SH, LM, CB	48	42	36	4	18	32	Front 3 Back 5	14
Child Size Plot BM, ED, MP	36	30	24	4	18	20	Front 3 Back 5	14
Cremation Plot BM, ED, MP	36	30	24	4	18	20	Front 3 Back 5	14
DOUBLE PILLOW MONUMENT ON PLOT WITH GRADE BEAM								
Full Size Regular Plots BM, MP, NL, SH, LM, CB	96	90	90	4	18	86	Front 3 Back 5	14
Child Size Plot BM, ED, MP	72	66	66	4	18	62	Front 3 Back 5	14
Cremation Plot BM, ED, MP	72	66	66	4	18	62	Front 3 Back 5	14
DOUBLE PILLOW MONUMENT ON PLOT WITH NO GRADEBEAM INDIVIDUAL FOUNDATION REQUIRED								
Full Size Regular Plots BM, ED, MP, LM, CB	96	90	84	4	18	80	Front 3 Back 5	14
Child Size Plot BM, ED, MP	72	66	60	4	18	56	Front 3 Back 5	14
Cremation Plot BM, ED, MP	72	66	60	4	18	56	Front 3 Back 5	14
Additional Information								
<ol style="list-style-type: none"> 1) Maximum Height of Monument includes base height, die height and accessories that are situated at the top of the die (for example a pagoda ball). This combination cannot exceed 48" 2) Minimum thickness is measure at the bottom of the die where it is attached to the base. 3) Due to the nature of the regular cemetery daily operation, the maximum amount of graves a monument may span is two. The maximum size allowed for the foundation is 6 inches smaller than the combined widths of the graves. 								

BM-Beechmount Haven CB-Cloverbar	ED-Edmonton LM-Little Mountain	MP-Mount Pleasant	NL-Northern Lights	SH-South	
	Grave Width	Foundation	DIE		
	Size (")	Max. Length (")	Max. Length (")	Min. Thickness (")	Max Width (")
SINGLE FLAT MONUMENT BRONZE					
Full Size Regular Plots BM, ED, MP, NL, SH, LM, CB	48	42	36	Gussets required	18
Child Size Plot BM, ED, MP	36	30	24	Gussets required	18
Cremation Plot BM, ED, MP	36	30	24	Gussets required	18
DOUBLE FLAT MONUMENT BRONZE					
Full Size Regular Plots BM, ED, MP, NL, SH, LM, CB	96	90	84	Gussets required	18
Child Size Plot BM, ED, MP	72	66	60	Gussets required	18
Cremation Plot BM, ED, MP	72	66	60	Gussets required	18
SINGLE FLAT MONUMENT GRANITE					
Full Size Regular Plots BM, ED, MP, NL, SH, LM, CB	48	42	36	3	18
Child Size Plot BM, ED, MP	36	30	24	3	18
Cremation Plot BM, ED, MP	36	30	24	3	18
DOUBLE FLAT MONUMENT GRANITE					
Full Size Regular Plots BM, ED, MP, NL, SH, LM, CB	96	90	84	3	18
Child Size Plot BM, ED, MP	72	66	60	3	18
Cremation Plot BM, ED, MP	72	66	60	3	18
Additional Flat Marker Specifications- see PAGE 39					

BM-Beechmount Haven CB-Cloverbar		ED-Edmonton	MP-Mount Pleasant	NL-Northern Lights	SH-South			
		LM-Little Mountain						
	Grave Width	Founda tion	DIE			Granite Base		
	Size (")	Max. Length (")	Max. Length (")	Min. Thickness (")	Max Width (")	Max. Length* (")	Min. Height (")	Max . Width (")
SINGLE FLAT MONUMENT BRONZE ON GRANITE								
Full Size Regular Plots BM, MP, NL, SH, LM, CB	48	n/a	38	Gussets required	20	42	4	24
Child Size Plot BM, ED, MP	36	n/a	26		20	30	4	24
Cremation Plot BM, ED, MP	36	n/a	26		20	30	4	24
DOUBLE FLAT MONUMENT BRONZE ON GRANITE								
Full Size Regular Plots BM, ED, MP, LM, CB	96	n/a	86	Gussets required	20	90	4	24
Child Size Plot BM, ED, MP	72	n/a	62		20	66	4	24
Cremation Plot BM, ED, MP	72	n/a	62		20	66	4	24
Additional Flat Marker Specifications- see PAGE 39								

Additional Information

Additional Flat Marker Specifications:

- Due to the nature of the regular cemetery daily operation, the maximum amount of graves a monument may span is two. The maximum size allowed for the foundation is 6 inches smaller than the combined widths of the graves.
- Flat marker dies that are to be placed in a foundation must have a rough edge (balanced rocked pitch) Sawn sides are not permitted.
- Flat marker dies that are to be placed without a concrete foundation may have sawn sides but must be a minimum of 4 inches thick – these markers may not be placed on grade beams.
- Flat marker dies in concrete frames are not allowed on grade beams.
- Granite flat marker dies on a granite base with a rough edge (balanced rock pitch) are permitted on grade beams
- Bronze-on-granite flat marker dies with a rough edge (balanced rock pitch) are permitted on grade beams.
- All bronze-on-granite flat markers must have a minimum 2" clearance from the outside edge of the bronze to the outside edge of the granite and be a minimum of 4" in thickness.
- Flat bronze markers must be raised on the backs with gussets.
- Flat markers at the Head of the grave may include a vase at the time of production.
- Vases that are added after the production of the monument will require investigation of the site to determine if a vase may be added. Investigation and approval to be completed by City staff.
- The following are exclusively designated for bronze-on-granite flat markers:
 - Grandin Section, Northern Lights Cemetery
 - Estate Section, Mount Pleasant Cemetery
 - Autumn Glory Section, South Haven Cemetery
- Double, side-by-side plot flat markers wider than 5' must be a minimum of 8" in thickness.

Markers at the foot of a Grave

- Flat only
- No vases
- Only permitted on full sized graves
- Permitted only after marker at head of grave has been installed

BM-Beechmount Haven CB-Cloverbar	ED-Edmonton	MP-Mount Pleasant	NL-Northern Lights	SH-South	
	LM-Little Mountain				
Grave Width	Boot (City Install)	DIE			
Size (")		Max. Length (")	Min. Height (")	Min Width (")	
Military Upright Monuments					
Full Size Regular Plots ALL Cemeteries	48	31x11x6	15	39 (min 3" into boot)	3
Additional Information					
<ul style="list-style-type: none"> ▪ All military monuments must meet the criteria established by the appropriate military authorities. ▪ Military monuments are only permitted in cemetery upright monument sections. ▪ Military monuments may be modified to fit into permanent grade-beams or individual pads by reducing the height and encasing the monument in a concrete boot. ▪ The combined height of the boot, base and die cannot exceed 36". ▪ Military monuments on grade-beams or individual pads may not be placed upon a granite base. ▪ Lithochrome highlighting is permitted on military monuments if paid for by the memorial owner/family. ▪ All inscriptions must be a minimum height of 1 ½" above the ground. ▪ Flat Military Monuments are not acceptable in the "Fields of Honour" ▪ "Flat at Foot" Markers are acceptable when a Military Headstone is pre-existing. ▪ No Vases or Flowerbeds are permitted in the "Field of Honour" 					