

Guidelines for Developer Street Identification Sign Design

The identification of roadways within the City of Edmonton is essential to distinguish one roadway from another, provide guidance to vehicular traffic and provide an accurate location for the prompt response and way finding for emergency vehicles.

Studies have shown that certain font types and sheeting colors provide a higher conspicuity to motorists. Consistency throughout the City of Edmonton is paramount in maintaining high visible signage. These proposed changes will comply with Transportation Association of Canada (TAC) and Manual of Uniform Traffic Control Devices for Canada (MUTCDC) standards that the City of Edmonton follows.

The Transportation Operations Branch has determined that in order to manage the design of the street identification signs, limitations shall be implemented for decorative street identification signing.

There are two styles of street addressing signs that are used ALR-1 type and the ALR-2 type signs. Instances where ALR-5 signs are required at signalized intersections, they must be manufactured using the standard green background and silver letters and will be on a standard rectangle shape.

The following limitations will be implemented when determining sign design:

1. Letter fonts on the main address area must conform to MUTCDC standards. Any deviation from these standards must be approved by the Traffic Control Section of the Transportation Operations Branch. Sans serif type fonts (similar to Clearview 1B) are preferred with a stroke width of 1/2". Letter spacing must be a minimum of 100 kern.
2. Background sheeting colors will be limited to 3M Electro Cut colors, 1172 (Red), 1175 (Blue), 1177(Green), 1178 (Black) or 1179 (Brown). Message and border must be 3M Hi-intensity Prismatic sheeting and must be silver in color.
3. Sign supports will be limited to federal standard colors, Blue 15055, Black 17038 or Dark Green 14036 to coincide with the decorative street light standard.
4. Designs will be limited to the standard City of Edmonton street identification sign designs for ALR-1, ALR-1a, ALR-2 and ALR-2a (appendixes 1, 2, 4 and 5). Additional street identification sign designs will be limited to the 15 styles as shown in appendixes 10-14. The developer is permitted to place any type of identification logo in the areas which extend outside of the main address area of these additional 15 designs.

5. ALR-1 street identification sign sizes can be 60, 75 or 90 cm in length by 22.5 cm in height. ALR-1 series signs may be either 1, 2 or 3 panels in height to produce an overall height of 22.5 cm, 45 cm or 67.5 cm
6. ALR-2 street identification sign sizes can be 60, 75 or 90 cm in length by 15 cm in height. ALR-2 series signs may be 1, 2 or 3 panels in height to produce an overall height of 15 cm, 30 cm or 45 cm.
7. All requests for street identification signing shall be approved by the Traffic Control Section of the Transportation Operations Branch.

Approved: 

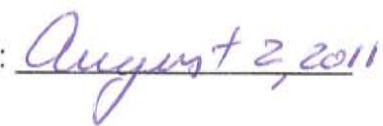
Date: 

Don MacDonald
Director, Traffic Control
Transportation Services

FRONT OF SIGN

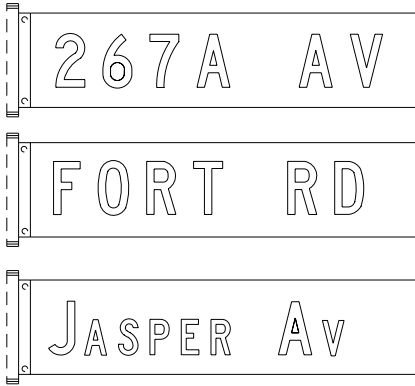

BACK OF SIGN

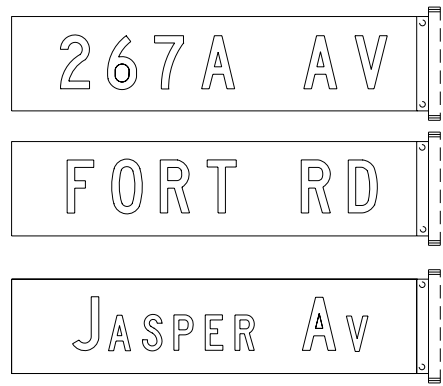

NOTE:

- Sign substrate material must be extruded aluminum I-plate, Alcan 6063 T6C, die 8654 or equivalent.
- Vertical dimension is 22.5 cm
- Horizontal dimension can be either 60 cm, 75 cm or 90 cm
- If the horizontal dimension of 90 cm is not adequate to accommodate the message, then use an ALR-1a or ALR-1aa.
- Named roads may start with capital letters 15 cm in height, and must be Clearview 1B type letters. The remainder of the message shall be not less than 10 cm in height and must be Clearview 1B type letters.
- Mounting bracket is to be installed on the left hand side of the front face.
- Reflective sheeting shall be the current standard used by the Transportation Operations Branch, Transportation Services.
- The message is to be printed on both sides of the blade.

TYPICAL ALR-1 SIGNS

COLOR

SYMBOL BACKGROUND

ALR-1	STREET BLADE	22.5 x 60	22.5 x 75	22.5 x 90	COLOR	
					SYMBOL	BACKGROUND
					SILVER	GREEN
					SILVER	GREEN
					SILVER	GREEN

DATE: June 21, 2011



TRANSPORTATION SERVICES

Appendix 1

APPROVED BY:

FRONT OF SIGN



BACK OF SIGN

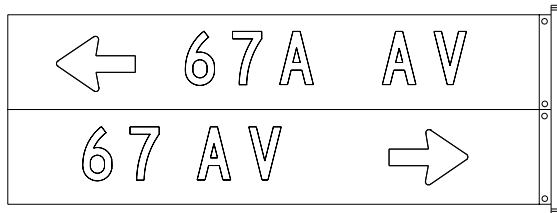
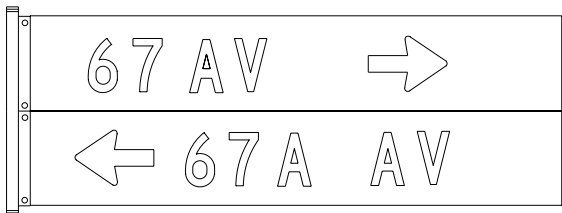
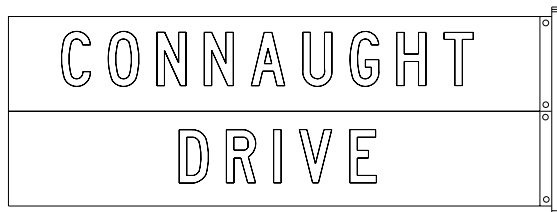

NOTE:

- Sign substrate material must be extruded aluminum 1-plate, Alcan 6063 T6C, die 8654 or equivalent.
- Vertical dimension is 2 X 22.5 cm
- Horizontal dimension can be either 60 cm, 75 cm or 90 cm
- If horizontal dimension of 90 cm is not adequate to accommodate the message, then use an ALR-1aa.
- Named roads may start with capital letters 15 cm in height, and must be Clearview 1B type letters. The remainder of the message shall be not less than 10 cm in height and must be Clearview 1B type letters.
- Mounting bracket is to be installed on the left hand side of the front face.
- Reflective sheeting shall be the current standard used by the Transportation Operations Branch, Transportation Services.
- The message is to be printed on both sides of the blade.

TYPICAL ALR-1a SIGNS

COLOR

SYMBOL BACKGROUND

TYPICAL ALR-1a SIGNS					COLOR	
					SYMBOL	BACKGROUND
ALR-1a		STREET BLADE	22.5 X 60	2 BLADES	SILVER	GREEN
			22.5 X 75	2 BLADES	SILVER	GREEN
			22.5 X 90	2 BLADES	SILVER	GREEN

DATE: June 21, 2011



TRANSPORTATION SERVICES

Appendix 2

APPROVED BY:

FRONT OF SIGN

BACK OF SIGN



NOTE:

- Sign substrate material must be extruded aluminum 1-plate, Alcan 6063 T6C die 8654 or equivalent.
- Vertical dimension is 15 cm
- Horizontal dimension can be either 60 cm, 75 cm or 90 cm
- If the horizontal dimension of 90 cm is not adequate to accommodate the message or if two names are required, then use an ALR-2a
- The message shall be 10 cm in height and must be Clearview 1B type letters.
- Mounting bracket is to be installed on the left hand side of the front face.
- Reflective sheeting shall be the current standard used by the Transportation Operations Branch, Transportation Services.
- The message is to be printed on both sides of the blade.

TYPICAL ALR-2 SIGNS

COLOR

SYMBOL	BACKGROUND
--------	------------

ALR-2	STREET BLADE	15 X 60	1 BLADE	SILVER	GREEN
		15 X 75	1 BLADE	SILVER	GREEN
		15 X 90	1 BLADE	SILVER	GREEN

DATE: June 21, 2011



TRANSPORTATION SERVICES

Appendix 4

APPROVED BY:

FRONT OF SIGN

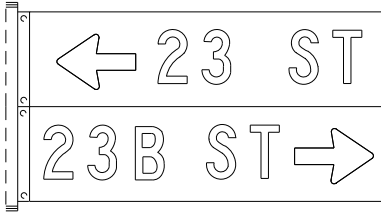

BACK OF SIGN

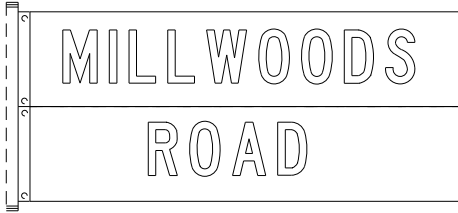
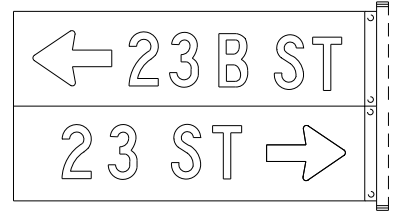

NOTE:

- Sign substrate material must be extruded aluminum I-plate, Alcan 6063 T6C die 8654 or equivalent.
- Vertical dimension is 2 X 15 cm
- Horizontal dimensions can be either 60 cm, 75 cm or 90 cm
- If horizontal dimension of 90 cm is not adequate to accommodate the message, then use an ALR-2aa.
- The message shall be 10 cm in height and must be Clearview 1B type letters.
- Mounting bracket to be installed on the left hand side of the front face.
- Reflective sheeting shall be the current standard used by the Transportation Operations Branch, Transportation Services.
- The message is to be printed on both sides of the blade.

TYPICAL ALR-2a SIGNS

COLOR

SYMBOL BACKGROUND

TYPICAL ALR-2a SIGNS						COLOR	
						SYMBOL	BACKGROUND
ALR-2a		STREET BLADE	15 X 60	2 BLADES		SILVER	GREEN
			15 X 75	2 BLADES		SILVER	GREEN
			15 X 90	2 BLADES		SILVER	GREEN

DATE: June 21, 2011



TRANSPORTATION SERVICES

Appendix 5

APPROVED BY:

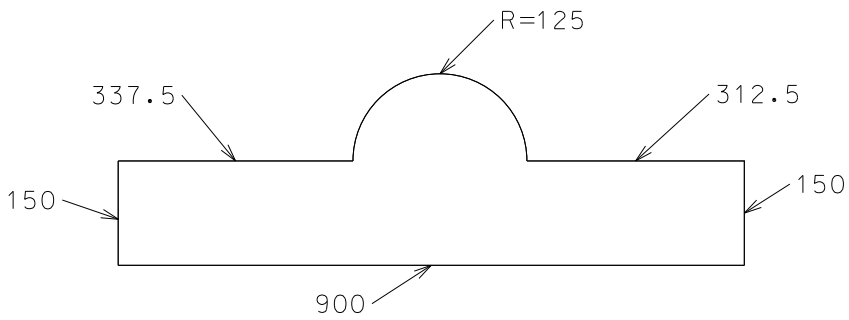

Design # 1

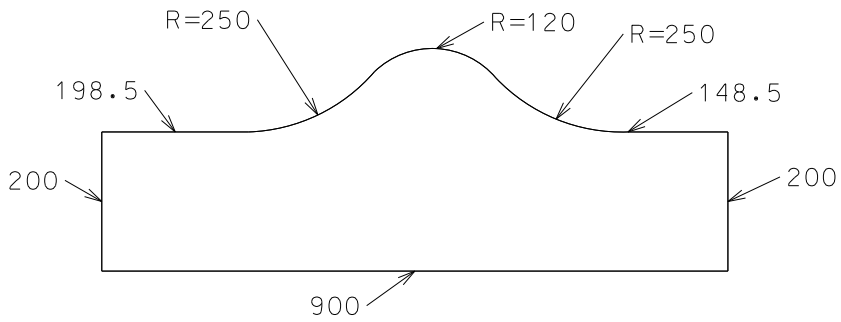

Design # 2

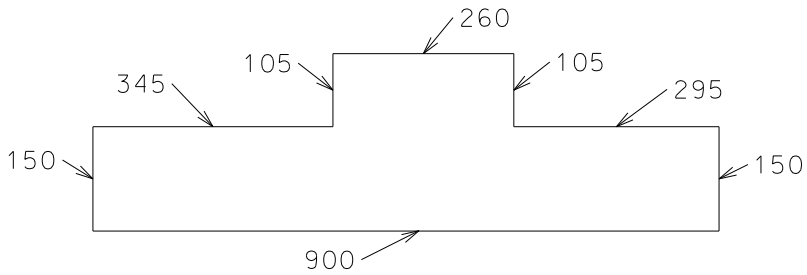

Design # 3

Decorative Street Blade Designs

COLOR

SYMBOL BACKGROUND

Design 1

15 cm X 90 cm

Design 2

20 cm X 90 cm

Design 3

15 cm X 90 cm

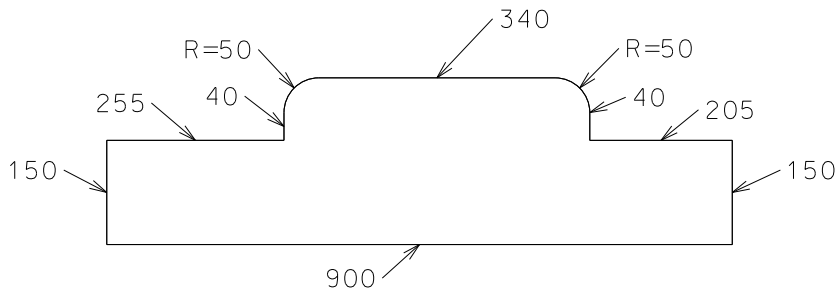

Design # 4

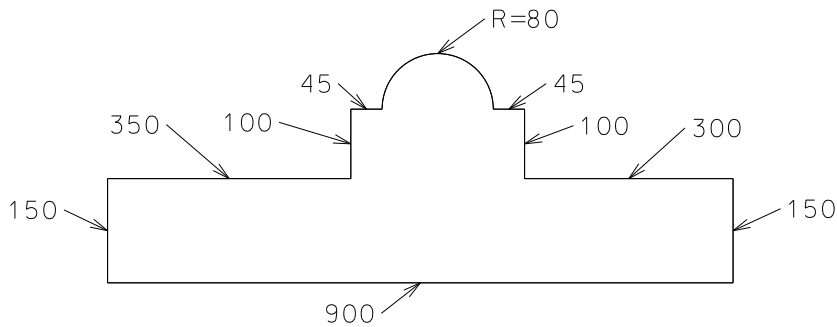

Design # 5

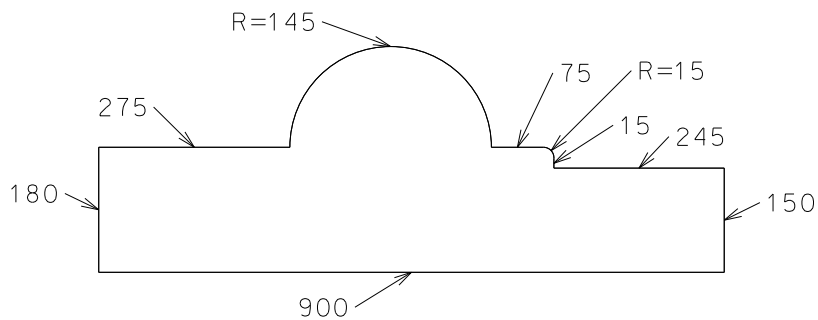

Design # 6

Decorative Street Blade Designs

COLOR

SYMBOL BACKGROUND

Design 4

15 cm X 90 cm

Design 5

15 cm X 90 cm

Design 6

15 cm X 90 cm

DATE: June 21, 2011



TRANSPORTATION SERVICES

Appendix 11

APPROVED BY:

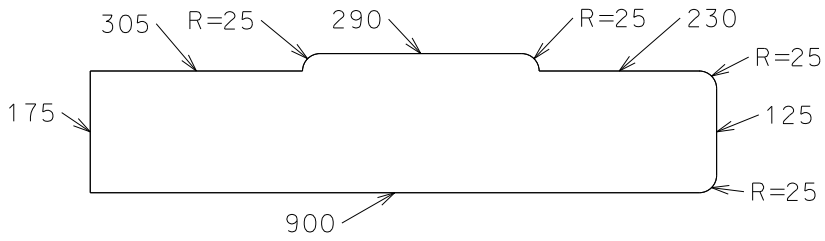

Design 7

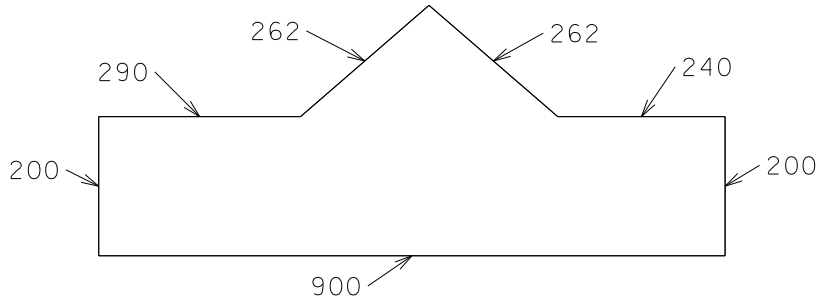

Design 8

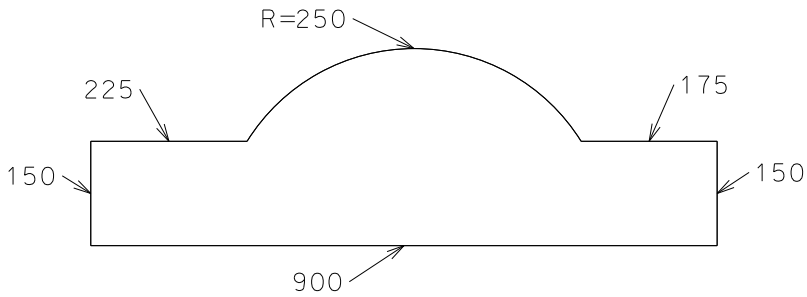

Design 9

Decorative Street Blade Designs

COLOR

SYMBOL BACKGROUND

Design 7

17.5 cm X 90 cm

Design 8

20 cm X 90 cm

Design 9

15 cm X 90 cm

DATE: June 21, 2011



TRANSPORTATION SERVICES

Appendix 12

APPROVED BY:

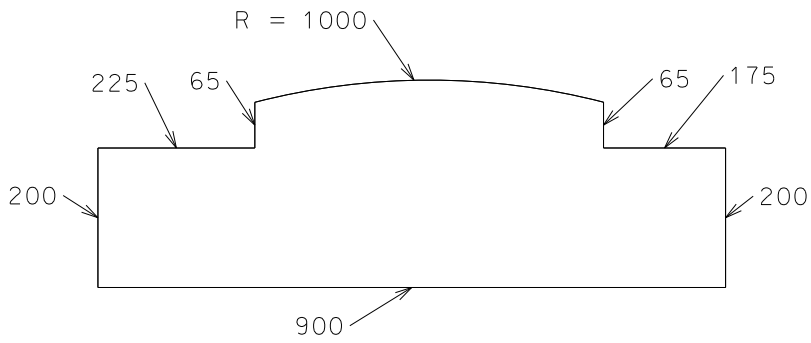

Design 10

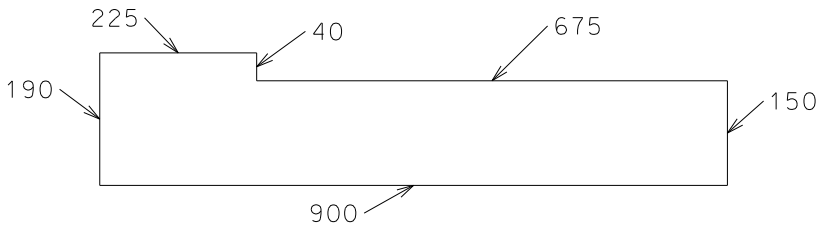

Design 11

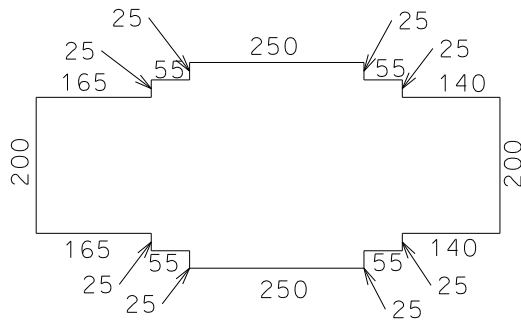

Design 12

Decorative Street Blade Designs

COLOR

SYMBOL BACKGROUND

Design 10

20 cm X 90 cm

Design 11

15 cm X 90 cm

Design 12

20 cm X 66.5 cm

DATE: June 21, 2011



TRANSPORTATION SERVICES

Appendix 13

APPROVED BY:

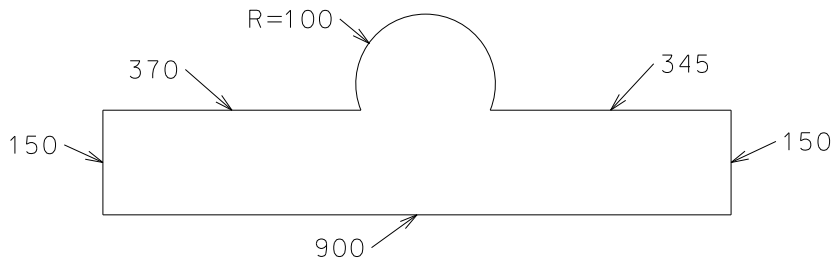

Design 13

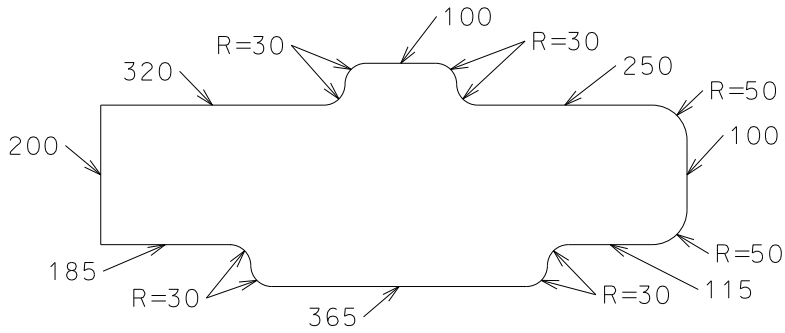

Design 14

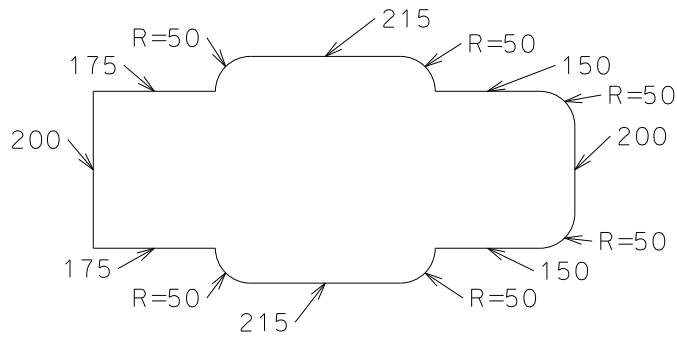

Design 15

Decorative Street Blade Designs

COLOR

SYMBOL	BACKGROUND
--------	------------

Design 13			15 cm X 90 cm		
Design 14			20 cm X 77.5 cm		
Design 15			20 cm X 69 cm		