

Table of Contents

1	INTRODUCTION.....	1
1.1	Manual Format.....	1
1.2	Definitions	1
1.3	Abbreviations.....	1
1.4	Consultant Qualifications	2
2	Specific Design Requirements	2
2.1	TAC Chapter 1 Supplement - Introduction.....	2
2.2	TAC Chapter 2 Supplement - Vision and Fundamental Concepts.....	2
2.3	TAC Chapter 3 Supplement - Obtrusive Light	3
2.4	TAC Chapter 4 Supplement - The Planning and Design Process	3
2.5	TAC Chapter 5 Supplement - System Components and Common Design Elements	9
2.6	TAC Chapter 6 Supplement - Standards and Codes	17
2.7	TAC Chapter 7 Supplement - Computer Applications	17
2.8	TAC Chapter 8 Supplement - Maintenance and Operations.....	17
2.9	TAC Chapter 9 Supplement - Roadways and Interchanges	17
2.10	TAC Chapter 10 Supplement - Intersections	18
2.11	TAC Chapter 11 Supplement - Roundabouts	18
2.12	TAC Chapter 12 Supplement - Mid-Block Crosswalks.....	18
2.13	TAC Chapter 13 Supplement - At-Grade Railway Crossings.....	18
2.14	TAC Chapter 14 Supplement - Tunnels.....	18
2.15	TAC Chapter 15 Supplement - Toll Plazas.....	18
2.16	TAC Chapter 16 Supplement - Off-Roadway Facilities	19
2.17	TAC Chapter 17 Supplement - Roadway Sign Lighting	19
2.18	TAC Chapter 18 Supplement - Streetscapes.....	19
2.19	TAC Chapter 19 Supplement - Temporary Roadway and Work Zone Lighting	19

List of Figures

Figure 1 - Existing Tree Assessment and Mitigation.....	14
Figure 2 - Example Foundation on Bridge Structure.....	15
Figure 3 - Example of Conduit on Bridge Structure.....	16
Figure 4 - Entrance Feature Lighting Examples.....	17

1 INTRODUCTION

This design manual defines road and walkway lighting design requirements specific to the City of Edmonton. No deviations from these standards will be permitted without written approval of the City of Edmonton Director of Signals, Street Lighting and Infrastructure.

This manual must be referenced to and interpreted simultaneously with all other City standards, bylaws, procedures and documents pertinent to works described herein. Such City standards and procedures include, but are not limited to, the current editions of:

- Road and Walkway Lighting Construction and Material Standards
- Design and Construction Standards - General Provisions
- Design and Construction Standards - Volume 2 Roadways
- Design and Construction Standards - Volume 7 Underground Power Distribution Systems
- Edmonton Procedures for On-Street Construction Safety

Where conflicts arise between other standards referenced, this design manual shall take precedence.

1.1 Manual Format

This manual is a supplement to the Transportation Association of Canada (TAC) Guide for the Design of Roadway Lighting and shall reference each Chapter from the TAC Guide and define variations, additional requirements and processes specific to the City.

1.2 Definitions

In this manual, any words implying male persons shall include female persons and corporations. In this manual, any words used in the plural include singular and visa versa.

1.3 Abbreviations

Abbreviations are as follows

APEGGA	Association of Professional Engineers, Geologists, and Geophysicists of Alberta
BRZ	Business Revitalization Zone
CEC	Canadian Electrical Code (Part 1)
CCC	Construction Completion Certificate
CSA	Canadian Standards Association
FAC	Final Acceptance Certificate
IESNA	Illuminating Engineering Society of North America
IMSA	International Municipal Signals Association
NEMA	National Electrical Manufacturers Association
TAC	Transportation Association of Canada
WCB	Workers' Compensation Board

1.4 Consultant Qualifications

The consultant undertaking lighting and electrical designs on road and walkway projects within the City must be qualified and meet the requirements listed below.

The consulting firm must:

- Employ engineer(s) registered with the Association of Professional Engineers, Geologists, and Geophysicists of Alberta (APEGGA) who will be required to sign and seal all lighting and electrical design drawings.
- Maintain a current Permit to Practice from the Association of Professional Engineers, Geologists, and Geophysicists of Alberta (APEGGA.)
- Maintain a current City of Edmonton Business License.

The City may audit the consultant to confirm they meet the requirements listed above. Failure to meet requirements listed may result in the consultant being restricted from undertaking projects within the City.

The consultant shall be knowledgeable in walkway and roadway lighting design, including products and construction methods as well as related aspects of the Canadian Electrical Code.

Though not mandatory, the consultants are encouraged to obtain International Municipal Signal Association (IMSA) Level II Roadway Lighting Certification, maintain membership with the Illuminating Engineering Society of North America and attend related conferences and meeting to stay current of roadway lighting trends and technologies.

2 Specific Design Requirements

The road and walkway lighting system in the City of Edmonton is operated by the Transportation Operations Branch of the Transportation Department. The Director of Signals, Street Lighting and Infrastructure in this branch has final responsibility for the interpretation, application and amendment of this manual.

All lighting designs shall be undertaken in accordance with the current edition of the Transportation Association of Canada (TAC) Guide for the Design of Roadway Lighting. These standards are written as supplement and shall be read in conjunction with the TAC Guide for the Design of Roadway Lighting. Those undertaking lighting designs on roads or walkways within the City of Edmonton must be knowledgeable of all parts of the TAC Guide for the Design of Roadway Lighting.

All designs must conform to the Canadian Electrical Code.

The design elements and requirements which supplement the TAC Guide for the Design of Roadway Lighting are as follows:

2.1 TAC Chapter 1 Supplement - Introduction

As it applies to the City of Edmonton this Chapter is primarily informational.

2.2 TAC Chapter 2 Supplement - Vision and Fundamental Concepts

Chapters 2.1 to 2.6 are mainly informational and shall be referred to by those requiring an understanding of lighting principals. Specific information noted in Chapter 2.7.8 shall apply with the following clarifications / changes noted below:

- For high pressure sodium lighting the City uses a 5 year maintenance cycle (re-lamping/cleaning), therefore it requires a 0.73 light loss factor be applied.
- Other light sources will require a suitable light loss factor to be included in the calculations.

Chapter 2.9 is not applicable to the City.

2.3 TAC Chapter 3 Supplement - Obtrusive Light

This Chapter defines general requirements and issues associated with obtrusive light, as it relates to roadway and walkway lighting. Specific to the City, all luminaires shall have cutoff or full cutoff optics to reduce up-light and glare. Some existing luminaires will not meet a cutoff or full cutoff classification. Where such lighting is being extended, the non conforming luminaires may be used with written approval from the City of Edmonton Director of Signals, Street Lighting and Infrastructure. The consultant will be responsible for making a case to use non-conforming luminaires and obtaining the approval in writing.

The consultant shall select luminaires with optical systems which efficiently lights up the road and walkway and minimize spill light off the road and walkway. This can be done by analyzing luminaire optical systems using methods defined in Illuminating Engineering Society TM-15 Classification System for Outdoor Luminaires and Addendum A: Backlight, Uplight, and Glare (BUG) Ratings. The analysis can be undertaken using photometric calculation software such as AGi32 Photometric Toolbox - Professional Edition. When assessing luminaires, ambient light sources shall not be considered.

2.4 TAC Chapter 4 Supplement - The Planning and Design Process

This Chapter defines the general planning and design process. Most of the information contained within Chapter 4 is informational and general in nature and shall be used where applicable.

The consultant shall follow the specific design process defined in Figure 4-3 - The Design Process in Chapter 4 of the TAC Guide for the Design of Roadway Lighting.

The City may audit the consultant's design practices and quality control process. The City will review the designs for general conformance, however, is not responsible for detailed plan checking and finding errors and omissions.

Upon starting any project, the consultant shall inform the City Director of Street Lighting and Signals in writing of the project location, scope of lighting and schedule.

2.4.1 Drawing Requirements

The consultant shall produce street lighting drawings on A1 size sheets using current versions of MicroStation or AutoCAD. Consultants shall prepare separate, distinct electrical drawings for the lighting system.

2.4.1.1 General Drawing Overview

Lighting design drawings shall show all civil drawing information such as curbs, sidewalks, property lines, utilities, landscaping, entrance features, all physical features that may impact the lighting design, as well as the lighting poles, conduit and wiring. Alternately these features may be included in the overall engineering design drawings for the project. Lighting drawings shall fully describe the proposed installation and all related existing lighting and electrical. The detailed information required on the drawings shall include, but not be limited to, the following:

- Plan drawings at a scale of 1:1000 (or alternate scale as deemed necessary by the City) showing pole locations, conduit, cables, and service equipment. Poles and service equipment shall be located by coordinate. Conduit and cables shall be located by offset from edge of pavement or curb and gutter.

1. All drawings shall show cabinets (with amperage). Two separate plans (primary power plan and secondary street light plan) shall be provided to improve plan readability and content for all power and street light specific information.
 2. Provide detailed cross section of roadway (with offset, lane width, number of lanes, median width, underground utilities), street light pole, pole base and conduit details are to be included.
 3. Separate designs for interim and ultimate alignments shall be shown.
- Legend and notes
 - Pole elevation and foundation detail
 - Drawings shall include sufficient street name and land or block location information to identify particular sections of road referenced in the lighting design summaries. The consultant may use block and lot information if road names have not been assigned at the time that the design is submitted.
 - Drawings shall show a list of recognized products. The list shall include specific products such as luminaires, lamps, poles, breakaway base and related hardware and service panels by manufacturer make and model #'s.
 - All lighting drawings shall be stamped and signed by a Professional Engineer registered with APPEGA.

2.4.1.2 Specific Drawing Elements

2.4.1.2.1 Street Light Pole Spacing

- The City requested all plans indicate the pole locations on the plans or in the notes.
- Pole locations in residential subdivisions are not typically equal, but rather are in-line with property lines.
- Coordinates of the poles in residential subdivisions shall be noted on the drawings

2.4.1.2.2 Pole Offsets

- Pole offsets can be identified by note with all exceptions noted on the drawings.

2.4.1.2.3 Luminaire Symbol / Pole Base Symbol

- Luminaire wattage, pole height and luminaire orientation shall be shown on the drawings and in legend for each pole type.

2.4.1.2.4 Ground Symbol

- All poles and services with a ground rod shall be identified with a ground symbol on the drawings or identified in the notes.

2.4.1.2.5 Cable Type

- Cable type shall be identified in the legend.

2.4.1.2.6 Conduit

- The type and size of all conduits and whether trenched or installed via trenchless technology shall be specified in the legend and notes.

2.4.1.2.7 Base Type

- The drawings shall identify pre-cast or poured-in-place base types in the legend.

2.4.1.2.8 Fillcrete Specifications

- The drawings shall identify where minimum 0.4 MPa fillcrete is required for bases shall be specified in the notes and legend.

2.4.1.2.9 Base Grade

- Drawings to identify a pole base grade of 100mm to 150mm above final grade shall be specified in the notes.

2.4.1.2.10 Minimum Power Line Clearances

- Power line clearances shall meet the minimum requirements in the Alberta Electrical and Communication Utility Code and the Canadian Electrical Code.

2.4.2 Supplemental Specifications

Supplemental specifications may be used to define and describe changes or additions to the City's Road and Walkway Lighting Construction and Material Standards Manual. Supplemental specifications may also define payment methods and other contractual elements.

Supplemental specifications shall generally follow the National Master Specification format and be printed onto 8.5 x 11 pages. Supplemental specifications may also be shown on the drawings.

2.4.3 Design Folders

Design folders shall provide specific information to allow the City to review and comment on the design. As a minimum the Design Folder shall contain:

2.4.3.1 Project Information

- Project title and number
- Project location
- Project description
- Key correspondence
- List any unique elements
- Items which deviate from City Standards and normal practices
- Names of consultants, key contacts and phone numbers
- Site pictures
- Lighting design criteria table
- Computer lighting calculations and photometric files including CSA C653 cobra head luminaire assessments
- Voltage drop calculations
- Letter from Geotechnical Engineer confirming soils conditions are suitable for foundations selected. Letter shall be signed and sealed by an Engineer registered with APEGGA.

Design folders shall be prepared in a well organized and easy follow digital format and printed onto 8.5 x 11 pages. Design folder shall be signed and sealed by a Professional Engineer registered with APEGGA.

2.4.4 Design Submissions

Once a design is completed it may be submitted to the City for review. All reviews must be completed and comments addressed prior to any design going to construction. Design submissions shall be sent to the City of Edmonton Director of Signals, Street Lighting and Infrastructure.

Submissions shall include:

- One (1) submittal letter on the consultant’s letterhead, signed by the consultant. As a minimum the letter shall define what is being submitted, provide general information on the project and its construction schedule and a list of specific elements and issues;
- One (1) full size set of drawings;
- One (1) set of supplemental specifications (if any);
- One (1) design folder.

The City may call for any additional information it deems necessary for the proper review of a design submission.

2.4.5 Review Process

The consultant is responsible for submitting the package for review in a timely manner to meet project schedules. The consultant is advised that the City’s plan review process consists of a 21 day and 5 day submission. Incomplete or unaddressed comments from the City will require further submissions. Please refer to Planning and Development review process.

The City will undertake a very general review of designs for general conformance with City standards. The City review does not negate the consultant’s responsibility for designs which do not meet requirements or perform as designed.

The City will sign and return all reviewed designs with or without comments to the consultant. Where acceptable to the City, the designs shall be noted as “reviewed” and will be signed off accordingly and can proceed to tender and construction. All designs not meeting the City’s requirements, as outlined in this manual, will be returned unsigned and noted “Make changes noted” and must be revised and resubmitted. When resubmitting, the consultant must respond to all comments and upgrade submittal as required. Where changes are required, the consultant may wish to review comments with the appropriate City staff.

2.4.6 Tendering

Tendering may be conducted by either the owner or the consultant, depending on the nature of the project. The consultant may directly select a contractor on behalf of the owner.

In special circumstances where the work may be of an overly complex nature, it is recommended a mandatory tender meeting be held to review the project, documents and respond to questions from the contractors.

The consultant shall respond to all contractor inquiries and questions through the tender period and, if required, issue any required Addenda.

2.4.7 Construction

The consultant shall provide construction services to ensure the work is completed as designed. The consultant shall take a pro-active role in construction, highlighting potential issues and concerns in advance of construction.

Key elements of the consultant’s work include:

2.4.7.1 Issue For Construction Drawings

The consultant shall provide “Issue for Construction” drawings which include all addenda or other required changes or clarifications. The consultant shall provide the City, contractor and other stakeholder with “Issue for Construction” drawings upon award to chosen contractor. If no changes were made to the tender drawings, then the tender drawings can be stamped as “Issued for Construction” with the required number of copies issued.

2.4.7.2 Pre-Construction Meeting

Though not mandatory, it is recommended the consultant conducts or, if part of roads project, attends the Pre-Construction meeting. This will allow the consultant to draw attention to specific requirements, issues, risks or concerns in advance of construction. In the case of some smaller project this may be done by a phone call.

2.4.7.3 Respond to Request for Design Clarification or Information

Contractors will, from time to time, require clarification as to specific design or construction elements of the project. The consultant or owner shall respond to such requests and provide clarification as required. If the request is in a written form it shall be responded to in writing and if discussion is required it shall be undertaken by phone or face to face and documented in the response. In all cases the request shall be responded to with copies to the required City staff and other stakeholders. All requests and responses shall be documented and retained by the consultant or owner for future reference.

2.4.7.4 Shop Drawings and Product Information Sheets

Shop drawings and product information sheets may be requested for non-standard materials such as luminaires, lamps, poles, service cabinets and breakaway bases. Standardized materials specifically defined (such as conduit, wiring, photo-controls, fuses, connectors, etc.) may also be requested.

Shop drawings and product information sheets shall be submitted to and shall be reviewed by the owner or consultant and returned to the contractor prior to construction. **Note - Shop drawings and product data sheets shall be “reviewed for general compliance” by the consultant or the City/owner. The contractor is however responsible for confirming all requirements are met.**

The consultant shall compile and distribute any required shop drawings to the City of Edmonton Director of Signals, Street Lighting and Infrastructure.

2.4.7.5 Design Adherence Reviews

The consultant or owner shall review the lighting installation to ensure that it conforms to the design and performs as required. The consultant or owner shall review the work and installation on an as-needed basis. Where deficiencies and non-conformances are found, they shall be reported in writing to the contractor.

The owner’s responsibility ends only on formal hand-over of the project to City ownership (Final Acceptance Certificate is issued). This will occur at the expiration of the contractor’s warranty period, once all deficiencies have been repaired and all formalities regarding completion certification have been completed to the City’s satisfaction.

Quality of work includes quality of materials used and also quality of workmanship. The owner is responsible for both elements and shall undertake such inspections and tests deemed necessary to ensure neither is compromised. The consultant shall review the results of all inspections and tests and advise if corrections or further testing is required.

All new work on the street and walkway lighting system shall be done to the Canadian Electrical Code (CEC). The consultant shall ensure that the Contractor has the requisite permits. The contractor shall pay all the applicable permit and inspection fees.

Accountability for the design and subsequent installation rests with the consultant. Any other inspections deemed necessary to ensure the quality of the furnished installations shall be done by the consultant or by qualified field inspectors responsible to the consultant.

All required documentation shall be submitted with the CCC as part of the Construction Folder.

Construction Folder shall include:

- Complete plan showing construction and design
- Concrete and Fillcrete compressive strength Reports and Delivery tickets (one test per supplier per day)
- Pole manufacturer Quality Control Reports
- Galvanizing Quality Control Reports
- Powder Coating Quality Control Reports and 7 Year Transferable Warranty. Also included shall be a letter signed by the supplier listing the date of delivery and that coatings meet all City requirements.
- Backfill Compaction Tests (as per Section 2318 of the Design and Construction Standards)
- Electrical Ground resistance testing Reports
- EPCOR application for un-metered service
- Electrical permit (see Section 1.5 of Construction and Materials Manual)
- Electrical Inspection Agency recognized by the City.
- Shop drawings and product information sheets for all non-standard products.
- Record drawings in hardcopy and digital format (MicroStation) complete with NAD 83 MicroStation 2D grid coordinates in an Excel seed file template (template provided by the City). All record drawings supplied to the City must show final locations of poles, transformers and service cabinets. This information must be surveyed by the contractor.

The Construction Folder shall be included with the initial CCC application. If any of the Construction Folder documentation is not included or not compliant, the City may reject the CCC application without inspection

2.4.7.6 Design Changes

In the event changes are required to the issue for construction design, the consultant shall be responsible for updating and resubmitting drawings to the City and the Contractor.

The consultant must receive City acceptance of proposed design changes before authorizing the contractor to undertake any work.

2.4.7.7 Post Construction

On completion of the lighting system and verification from the contractor all random tests that construction deficiencies have been rectified, the consultant shall submit to the City:

- Construction Completion Certificate (CCC) filled out by the consultant and reviewed and accepted by the City. A copy is located in the Appendix. The Permit to Practice shall be signed off by the consultant.
- Record drawings in hardcopy and digital format (MicroStation) complete with NAD 83 MicroStation 2D grid coordinates in an Excel spreadsheet. The contractor shall survey final locations of poles, transformer and service cabinets and upgrade drawings and prepare an Excel spreadsheet with coordinate information.

The issuance of the CCC shall start the warranty period. At the expiration of the warranty period (24 months), the consultant shall verify that all lights are functioning correctly and provide the City of Edmonton Transportation Operations Branch, Transportation Department confirmation in writing. If the system is operating with no deficiencies, the City will issue the Final Acceptance Certificate (FAC) based on the letter submitted by the consultant. If there are still outstanding deficiencies, the City shall delay the issue of the FAC until such time all deficiencies have been rectified to the City's satisfaction.

The FAC shall be filled out by the contractor and reviewed and accepted by the consultant. A copy is located in the Appendix. The Permit to Practice shall be signed off by the consultant.

Upon acceptance of the FAC, the lighting system shall be taken over by the City. At this point, the City will pay all ongoing maintenance costs.

2.5 TAC Chapter 5 Supplement - System Components and Common Design Elements

The City has specific materials and installation methods which are defined in City of Edmonton Road and Walkway Lighting Construction and Material Standards Manual. Specific material and construction information shall be superseded by the City of Edmonton Road and Walkway Lighting Construction and Material Standards Manual.

2.5.1 Materials and Equipment

Materials and equipment proposed for use on the City's road and walkway system shall conform to the requirements of these manual and the City Road and Walkway Lighting Construction and Material Standards Manual. Particular attention will be paid to luminaires and their photometric performance, durability, quality and ease of maintenance.

The Director may limit the styles and types of materials and equipment used on the road and walkway system. This includes materials and equipment for Business Revitalization Zone (BRZ) projects.

Once approved for a specific project, materials and equipment may be listed on the City's Recognized Lighting Product List and may subsequently be used on other projects elsewhere in the City, provided there is no change to the physical construction or performance of the equipment. When a manufacturer changes their product or alters its performance characteristics, the City approval for the product may be voided and the product must be re-submitted for pre-approval.

In the event that new materials and equipment or first time materials and equipment are required, the consultant shall assemble all product data and drawings and submit them for review by the City of Edmonton Director of Signals, Street Lighting and Infrastructure. The consultant will provide supporting data, including life cycle cost analysis showing the long term benefits to be obtained by using the materials and equipment.

2.5.1.1 Luminaires

The types of luminaires and their mounting are defined in TAC Chapter 5.2 - Types of Lighting and Mounting. The most common types are cobra head style luminaires mounted on davit style poles and post top luminaires mounted on straight poles. As they apply to the City, both types are defined as follows:

- Cobra head style luminaires are typically used to light roadways. The consultant shall only consider luminaires which meet requirements noted in the City of Edmonton Road and Walkway Lighting Construction and Material Standards Manual and meet or exceed performance requirements list in CSA C653-08 Photometric Performance of Roadway Lighting Luminaires. The consultant shall submit CSA C653 analysis with lighting calculations.
- Post top style luminaires are typically used to light walkways. They come in many colors, styles and shapes. Refer to Recognized Product List or contact the Director of Signals, Street Lighting and Infrastructure for standard wattages and types of light sources.

Luminaires shall be selected for their photometrics, durability and quality, using optics that minimize spill light on adjacent properties and which significantly limit up-light.

2.5.1.2 Power Supply

EPCOR is the electrical utility which supplies power for the City street lighting system. The consultant shall contact EPCOR and confirm voltage and locations of suitable power sources for the proposed lighting system, as well as obtain a cost estimate for power supply. Utility feeds shall be confirmed and shown on the lighting design drawings.

2.5.1.3 Power Distribution

Lighting system shall be fed via a standardized lighting control cabinet which shall contain panel boards, breakers, lighting contactor(s), receptacle and switch and, where required, a transformer and / or a photocell. Road and walkway lighting systems shall be un-metered unless otherwise required by EPCOR or the City. Metering may be required where receptacles or other devices with varying loads are present.

The standardized cabinets and bases used by the City are as follows:

- 120/240V Residential Lighting Control Base with minimum 30A main breaker, lighting contactor and sub-panel with branch circuit breakers and switch. Refer to City of Edmonton Standard Drawings. It shall be used in residential subdivision applications. The Residential Lighting Control Base shall be placed between the pole and concrete base. Where using the Residential Lighting Control Base the pole shall be shorter by approximately the height of Lighting Control Base
- 120/240V Lighting Distribution/Control Cabinet with a 100A main breaker, panel board and a 100A lighting contactor. This cabinet mounts on a standard concrete base. Refer to City of Edmonton Standard Drawings. This cabinet shall be placed on a concrete base and used in applications outside of residential subdivisions.
- 120/208V, 347/600V or 277/480V Lighting Distribution/Control Cabinet with a 100A or 200A main breaker, panel board and a 200A lighting contactor. This cabinet mounts on a standard concrete base. Refer to City of Edmonton Standard Drawings. This cabinet shall be used in applications outside of residential subdivisions.

A cabinet shall be placed where it is unlikely it will come in contact with a motor vehicle. It shall be at least 1.25m from the roadway where behind curb and gutter and at least 3m off the roadway where no curb and gutter is present. The cabinet's location shall not obstruct a driver's view of pedestrians crossing the road. Doors shall face away from the roadway to avoid water splash when working in the cabinet.

The consultant shall provide a riser diagram on drawings which defines maximum allowable fault current, number and sizes of breakers and contactors, wiring, etc.

2.5.1.4 Wiring to Poles

The consultant shall use 120/240V or 120/208V voltages and may use 277/480V or 347/600V with the approval of the Director of Signals, Street Lighting and Infrastructure. All circuits shall be designed as phase to neutral. No line to line voltages will be allowed.

The consultant shall design the circuits feeding the street lights in strict accordance with the provisions of Canadian Electrical Code (CEC), Part 1 (latest revision). This shall include, but is not limited to:

- The sizing of conductors to suit the ultimate load and the ampacity ratings of the breakers. When more than 3 conductors are included in a conduit the conductors ampacity shall be de-rated (refer to Table 1 to 5 in the Canadian Electrical Code, Part 1 when sizing and de-rating conductors);
- Sizing of the bond wire. The size of the bond wire shall also be based on the ampacity of the largest conductor. This will be an issue where voltage drop requires conductors be up sized (refer to Table 16 in the Canadian Electrical Code, Part 1 when sizing the bond wire)

Wiring shall be stranded copper Teck90 (XLPE), -40C, 1000V cable suitable for direct bury. Minimum conductor sizes shall be #12 AWG. For residential subdivisions wiring can be USEB-90 cable with stranded aluminum conductor(s), black cross-linked polyethylene insulation, color-coded PVC, 600V to CSA C22.2 No. 129.

The consultant shall design and specify wiring and related electrical components on the drawings. Wire sizing shall take into account future extension and additional loads. This is particularly important when considering future circuit loading on staged construction projects to provide adequate circuit capacity through to the ultimate stage.

2.5.1.5 Conduit

Conduit shall be used as a chase for new TECK or USEB cables into concrete bases, at road crossings. Conduit shall be 50mm or larger PVC (DBII) to accommodate TECK or USEB cables.

Conduits under existing paved roadways shall be installed via a suitable trenchless technology to avoid cutting the existing asphalt. Cutting asphalt and trenching of the roadway will only be considered where the asphalt replacement is part of the project. Open cutting of asphalt and open trenching across existing asphalt must be noted on the drawings and reviewed by the City of Edmonton Director of Signals, Street Lighting and Infrastructure. Schedule 40 HDPE conduits may be used when installing conduit via trenchless technology.

2.5.1.6 Pole Bases

The City Standard Lighting Construction drawings define typical bases to go with standard lighting poles. Typical bases have been designed for soils conditions noted on the standard drawings. The consultant is responsible for determining the suitability of these standard foundations for the given soil's conditions. A geotechnical engineer must provide signed and sealed letter stating the suitability of the foundations for the given soil's conditions. Where foundations are not suitable, custom foundations shall be designed and detailed on the drawings. Custom foundations must be reviewed by the Director of Signals, Street Lighting and Infrastructure).

Bases may be poured in place, pre-cast, or screw-in type. Steel screw-in type pole bases may be used where agreed to in writing by the Consultant and the City. (All bases in the engineering drawings are permitted for use with the pole height described in the drawing title).

2.5.1.7 Poles and Related Hardware

Standard pole types and sizes are defined on the City standard construction drawings. All poles must be galvanized and may have powder coat finish applied to improve appearance.

Standard poles and general application are as follows:

- 4.9m (16 ft) and 6.1m (20 ft) post top pole - Walkways
- 7.92m (26 ft) davit pole with 0.60m (2 ft) lighting control base and 8.53m (28 ft) davit pole - 9m wide local residential roads, Downtown and River Valley areas.
- 9.14m (30 ft) davit pole with 0.60m (2 ft) lighting control base and 9.75m (32 ft) davit pole - Any roads over 9m wide in residential areas
- 10.97m (36 ft) davit pole - 11.5m wide and wider roads in non-residential areas
- 13.11m (43 ft) davit pole and 15.24 (50 ft) m davit pole - 14.5m and wider roads in non-residential areas.

Double davit poles may be used in medians where a minimum 3m clear zone is met. If the clear zone cannot be met, proper barrier protection must be provided. Poles 9.75m (32 ft) or less shall be used in residential area.

The City has typical Utility Location Plans in the City Design and Construction Standards for Roadways to define required lighting pole locations within the right-of-way. These drawings shall be referred to when defining pole offsets.

For high speed roadways (greater than 70 km/h) with no curb and gutter, clear zone shall be considered. Poles shall be placed outside the clear zone or breakaway devices shall be installed on the poles if it is not possible to position poles outside the clear zone. Refer to TAC Chapter 5.93 for specific Clear Zone requirements. Breakaway bases shall not be used in medians as poles may be knocked into oncoming traffic.

Where non-standard poles are used they must be fully engineered along with the concrete bases and meet the approval of the City of Edmonton Director of Signals, Street Lighting and Infrastructure.

Where overhead power lines are present, the consultant shall verify the height of the proposed or existing lines and provide poles which meet the required clearances to overhead power lines. Maintaining clearances to overhead and underground Utilities in accordance with Utilities Standards, Canadian Electrical Code, Workers Compensation Board and the Alberta Electrical Safety Act shall also govern pole location and height. Installing bracket arms of existing utility poles may also be an option where power line clearance cannot be achieved. Where overhead power lines are present and luminaire bracket arms are a consideration, EPCOR shall be contacted to review options.

2.5.2 Key Design Considerations

Listed below are some key design considerations which should be addressed as part of the consultant's design:

2.5.2.1 Pole Offsets

Poles shall be designed so they do not obstructive pedestrian movement on sidewalks. Poles shall be located to provide a minimum of 1.2m clearance on sidewalks to maintain wheel chair accessibility.

2.5.2.2 Design Optimizations

Designs shall meet and just exceed minimum performance criteria. Over designing should be avoided. The consultant shall provide justification for any lighting which is designed to be significantly above the required criteria. The option of decorative lighting shall not result in an increase in wattage and/or number of poles and luminaires.

The consultant will maximize pole spacing to suit intersections, driveways and lot configurations. This will involve selecting the pole height most appropriate to the lighting task and luminaires with efficient optics and then optimizing the spacing via computer lighting design software. Where possible street lights shall be placed at lot lines to avoid driveways, trees and utilities. Luminaires shall be the minimum wattage required to provide the desired lighting at the optimized pole spacing. The consultant shall conduct a number of calculations using a trial and adjust process using various pole/luminaire/light distribution combinations to determine the optimum arrangement.

To meet intersection light levels, luminaires shall be installed on all signal poles to minimize the number of poles required for a design. The pole spacing at intersections shall, therefore, be governed by the signal pole locations. Additional street light poles may be required to meet intersection lighting standards.

2.5.2.3 Impact for Landscaping and Trees

Trees and shrubs can block light and, thus, reduce lighting below required levels. All designs must take into consideration light blockage from landscaping and street trees. Where trees are proposed or exist they shall be considered in the lighting design.

Where trees are proposed lights may have to be installed on arms which extend out over the roadway beyond the ultimate tree canopy. Additional pedestrian scale lighting may be required for the sidewalk. The proposed locations, spacing, pole height, arm length and frequency of the trees may also need to be adjusted in conjunction with the lighting pole spacing. A tighter pole spacing than calculated may be required to compensate for anticipated light blockage resulting in additional poles and luminaires.

As noted in a July 2008 US Federal Highway report titled **Trees, Lighting, and Safety in Context Sensitive Solution** some examples of how a lighting system might be designed for the presence of trees at all stages of maturity include:

- Until more research is performed the best design approach is to locate luminaires outside of the full growth lines of the species of tree along the roadway.
- When a roadway or pedestrian lighting project includes new or existing trees in close proximity to the lighting, then an additional light loss factor should be included in the design for light loss due to shading. Insufficient research is available at this time to quantify the factor but 0.8 to 0.9 appears reasonable.
- In heavy pedestrian areas a combined system of higher roadway poles and lower pedestrian poles could yield a more consistent maintained lighting level throughout the stages of growth of trees.

These examples should be considered where trees are proposed or exist.

Where trees exist and impact the lighting tree pruning shall be considered. Figure 1 below shows the recommended procedure of assessing and mitigating the impacts of trees via pruning. Where pruning is required its viability shall be discussed with the Director of Signals, Street Lighting and Infrastructure. As trees vary in foliage, shape and size it is not practical to calculate the exact impacts.

Cable and conduit alignments shall be designed to avoid tree roots. Communication with the City of Edmonton is required for such issues that will compromise the lighting design, or conflict with any other infrastructure on City road right of way.

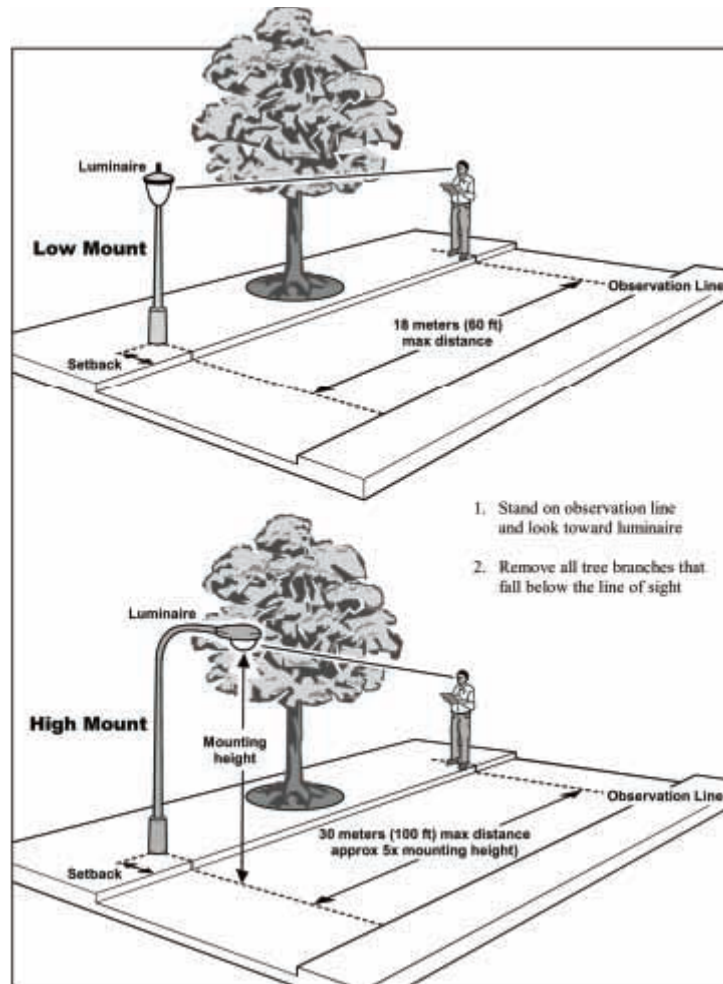

Figure 1 - Existing Tree Assessment and Mitigation

2.5.2.4 Half road Lighting

Where only half the road width is being constructed, the lighting shall be designed with ultimate pole arrangement to meet the road classification lighting design criteria. Lighting for half roads where a staggered or opposite pole spacing is required for the ultimate shall meet or exceed required lighting levels in the interim and shall be designed to meet ultimate lighting level requirement by adding additional poles on the undeveloped side.

2.5.2.5 Pedestrian Facilities

The task of lighting for pedestrian needs differs from roadway lighting in that there are no vehicles present and, therefore, no contribution from motor vehicle headlights. The lighting system must, therefore, provide all necessary lighting. Pedestrian walkways shall be designed to meet TAC horizontal illuminance and uniformity requirements. Walkway lighting equipment should be low maintenance and be inherently vandal resistant. Minimum acceptable mounting height for pole mounted luminaires is 4.88m, unless otherwise reviewed by the City of Edmonton Director of Signals, Street Lighting and Infrastructure.

2.5.2.6 Bridge Structures

Extensive coordination is required with bridge design engineers to ensure that conduits and light mounting points are incorporated into the bridge structure design.

Foundations for poles shall be designed as part of the bridge structure. Foundations shall be designed to attach to the bridge deck or parapets as shown on Figure 2 below. Foundations and poles shall be placed to allow for clear sidewalk passage.



Figure 2 - Example Foundation on Bridge Structure

Poles on bridges shall be designed to limit vibration from the bridge structure to the luminaire. Luminaires on bridges shall be designed with anti-vibration components and safety cables for additional connection to the pole.

Whenever possible, conduits shall be cast into the sidewalk, deck or parapet as shown in Figure 3. If this is not possible, conduits may be surface mounted to interior bridge members where they are out of view. Where conduit is mounted to the surface, it shall be galvanized rigid metal conduit or fiber reinforced conduit. Conduits on the bridge structure shall have suitable expansion/deflection fittings at abutments, expansion joints and points of differential settlement of the bridge.



Figure 3 - Example of Conduit on Bridge Structure

Where junction boxes are required, they shall be powder coated aluminum with a NEMA 4 rating and shall be accessible from the bridge deck or sidewalk for easy maintenance.

2.5.2.7 Entrance Feature Lighting

Where signs at the entrance of developments require lighting, they shall be illuminated to a low ambient level as defined in Chapter 17 of TAC.

Lighting can tie into and be controlled by the street lighting system and must be included in voltage drop calculations and street lighting design folder. Luminaires shall be of a vandal resistant design to accommodate mounting on or in the ground. Luminaires shall be placed on road right-of-way as close as possible to the entrance feature sign and must be aimed away from residences and roadways to minimize impact on vehicular traffic. Luminaires shall be specified as metal halide, high pressure sodium, or LED and have a minimum IP65 rating and shall have an external shielding or internal louver system to reduce glare impacts. Luminaires can either be adjustable above ground type or an in-ground type as shown in Figure 4. Luminaires shall be cast into or on concrete to reduce the potential for vandalism.

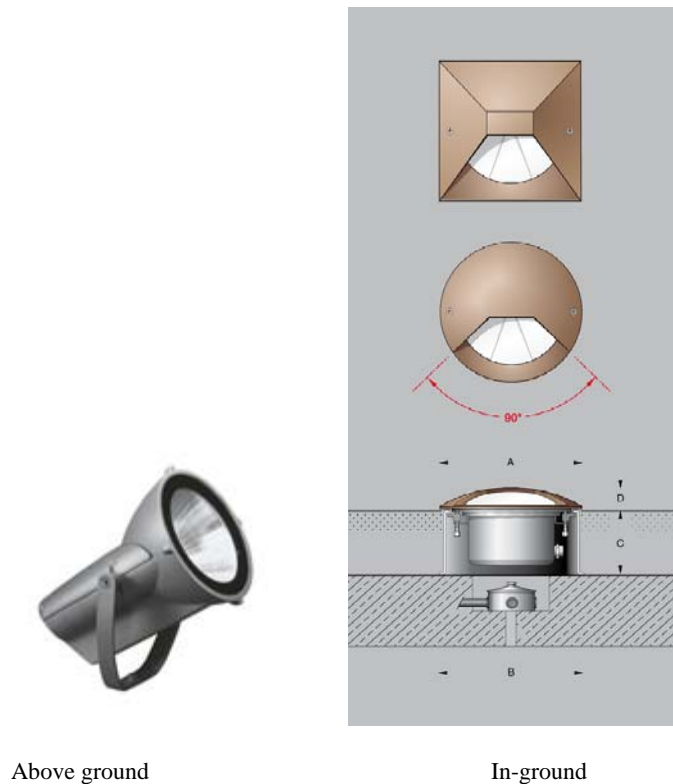

Figure 4 - Entrance Feature Lighting Examples

2.6 TAC Chapter 6 Supplement - Standards and Codes

This Chapter defines information on codes and standards which can be applied to street lighting system.

2.7 TAC Chapter 7 Supplement - Computer Applications

This Chapter defines general information on computer lighting design software and is not specific to the City of Edmonton. The City does not require the lighting designer use specific lighting design software provided it is suitable for the application.

2.8 TAC Chapter 8 Supplement - Maintenance and Operations

This Chapter defines general elements of maintenance and operations. Maintenance and operations is not part of these specifications, however, the consultant should be aware of operations and maintenance elements and considerations.

2.9 TAC Chapter 9 Supplement - Roadways and Interchanges

This Chapter defines specific requirements for lighting roadways and interchanges. This Chapter shall apply with the exception of the following:

- Under Chapter 9.4 Lighting Warrants shall not apply. Lighting will be required on all urban roads unless otherwise defined by the City. The need to light rural roads with open ditches with little or no pedestrian activity during hours of darkness shall be reviewed with the City.
- Under Chapter 9.6.2 luminance calculation will not be required on curved and steep grade roadways. Curved roadway sections (less than 160 meter radius) or roads with steep and variable grades (6% or greater) can be calculated using the horizontal illuminance method. Grids should be placed across the travel lanes at 2m spacing. The required lighting levels can be derived using the illuminance criteria defined in TAC Appendix A for the road classification / pedestrian activity under consideration.
- Under Chapter 9.6.4 vertical sidewalk illuminance calculations shall not apply.
- When undertaking lighting calculations on single or two lane roadways the maximum lane width used in the calculation shall be 4m. Where scenarios are encountered where the lane is over 4m, a 4m wide lane shall be applied for the travel portion of the roadway from centerline. This scenario will be common in residential subdivisions. Where part-time parking lanes exist or are proposed they shall be calculated as if they are full time general purpose lanes. Full time on-street angled or parallel parking where there is no chance the parking will be used as a travel lane shall not be included in the lighting calculations.

2.10 TAC Chapter 10 Supplement - Intersections

This Chapter defines specific requirements for lighting intersections. This Chapter shall apply with the exception of Chapter 10.4 Intersection Warrants shall not apply as all intersections require lighting unless specifically noted otherwise by the City.

2.11 TAC Chapter 11 Supplement - Roundabouts

This Chapter defines specific requirements for lighting roundabouts. All roundabouts shall be lighted unless specifically noted otherwise by the City. Roundabouts for intersecting local residential roads in subdivision may be illuminated in accordance with the intersection lighting requirements for local roads with low pedestrian activity as defined in Chapter 10.

2.12 TAC Chapter 12 Supplement - Mid-Block Crosswalks

This Chapter defines specific requirements for lighting mid-block crosswalks. All mid-block crosswalks shall be lighted unless specifically noted otherwise by the City.

2.13 TAC Chapter 13 Supplement - At-Grade Railway Crossings

This Chapter defines specific requirements for lighting at grade railway crossings. At grade railway crossings shall be lighted where warranted.

2.14 TAC Chapter 14 Supplement - Tunnels

This Chapter defines general requirements for lighting tunnels. Tunnels shall be lighted where warranted.

2.15 TAC Chapter 15 Supplement - Toll Plazas

Not applicable

2.16 TAC Chapter 16 Supplement - Off-Roadway Facilities

This Chapter defines specific requirements for off roadway facilities such as walkways, bikeways and parking lots. Information for lighting weigh scales and rest areas shall not apply.

2.17 TAC Chapter 17 Supplement - Roadway Sign Lighting

This Chapter defines general requirements for lighting signs. The illumination of signs shall be via retro-reflective sign sheeting material. The City may require specific signs be illuminated via sign luminaires.

2.18 TAC Chapter 18 Supplement - Streetscapes

This Chapter defines general requirements for lighting architectural features such as building faces, monuments, statues, etc above and beyond the lighting required for the roadway or sidewalk areas.

This lighting is more aesthetic than functional and is not typically specifically warranted by the City.

2.19 TAC Chapter 19 Supplement - Temporary Roadway and Work Zone Lighting

This Chapter defines general requirements for temporary roadway lighting and work zone lighting. Work zone lighting defines lighting for a contractor's work zone. Where work zone lighting is required, it should be reviewed with the contractor prior to construction, as improper work zone lighting can adversely impact driver visibility.

Temporary roadway lighting should be considered:

- on roads with speeds of 70km/h or greater;
- where roadway lighting exists and detours will be in place for a prolonged period as deemed by the City;
- where defined by specific project requirements;
- where deemed required by the City.