

PROCEDURES FOR ON-STREET CONSTRUCTION SAFETY



A close-up photograph of several yellow traffic lights. The lights are arranged in a cluster, with the foreground lights being in sharp focus and the background lights being blurred. The lights have a textured, circular lens with a grid-like pattern. The overall color palette is dominated by bright yellow and orange tones.

CONTACT INFORMATION

- 311 – City of Edmonton, Call Centre (24 HR)
 - 780-442-6458
- Information for:
- O.S.C.A.M. Permit Requests
 - Parking Meter Hooding Requests
 - Temporary Traffic Control Requests
 - Road Closures and Special Event Closures
- 1-800-242-3447 – Alberta 1 Call
 - www.edmonton.ca

TABLE OF CONTENTS

- 4 Introduction
- 4 Responsibilities
- 5 A Checklist Before Starting Work
- 6 Standards of Performance
- 7 O.S.C.A.M. Permits
- 8 Parking Bans
- 9 Parking Meters
- 9 Pedestrian Obstructions
- 10 Guide Traffic Around the Work Area
- 17 Channelization Devices
- 21 Flagperson Duties and Responsibilities
- 24 Procedures for Prosecution of Violations Against Flagpeople
- 25 Temporary Traffic Control
- 29 Symbols Used in Typical Situation Sketches
- 31 Examples of Typical Worksite Traffic Control Set-Ups
 - Series A
 - 33 A1 – Back Lane Closure
 - 34 A2 – Residential Road Closure
 - 35 A3 – Yield to Oncoming Traffic
 - 36 A4 – Single Left Lane Closure: Parking Permitted
 - 37 A5 – Single Single Lane Closure: No Parking Permitted
 - 38 A6 – Sidewalk Closure with Pedestrian Accommodated Lane Closure
 - 39 A7 – Two Lane Closure: Traffic Split
 - Series B
 - 41 B1 – Two Way Flagging Operation
 - 42 B2 – Flagging: Closure Short Duration
 - 43 B3 – Short Duration: Utility Operation
 - 44 B4 – Short Duration: Work at Signalized Intersection

INTRODUCTION

This Procedures Manual has been assembled by the Transportation Operations Branch of the City of Edmonton Transportation Department. It is a valuable guide for those who deal in any way with the complex transportation network of the City of Edmonton. It will also aid contractors and suppliers in defining the specifications and special provisions of tenders for on street construction.

The document is intended to be a practical, working booklet. The Manual identifies minimum safety precautions which should be taken at these worksites and is oriented towards ensuring the safety of all at the worksite.

This Manual sets out a uniform set of procedures which can be followed at work sites where some interference to traffic or pedestrian flows is anticipated.

When and where there may be a conflict between these regulations and the Occupational Health and Safety Act, the Occupational Health and Safety Act shall apply.

RESPONSIBILITIES

Transportation Operations Branch has the final authority to ensure proper placement of Temporary Traffic Control devices on road right-of-way. This authority is granted through Traffic Bylaw 5590.

The on-site agency and job site supervisor are responsible for obtaining, placing and maintaining temporary traffic control devices for all traffic interruptions on City road right-of-way (this includes work on boulevards and sidewalks). The responsibility of the on-site agency and the job site supervisor shall remain in place until final completion of the project. This includes any and all restoration work required.

Responsibilities also include:

- Proper Training (Certification)
- Proper Apparel
- Proper Inspection Procedures
- Proper Documentation

A CHECKLIST BEFORE STARTING WORK

These questions should be considered before beginning work on any road right of way;

- Have you applied for an On-Street Construction and Maintenance permit (O.S.C.A.M.) from the Transportation Operations Branch at 780-442-6458?
- Has approval been given for the traffic interruptions?
- Have you studied the nature of the traffic at the proposed worksite and understand what impact proposed temporary traffic control will have?
- Have you arranged for temporary traffic control devices (e.g. Signs, Barricades, etc.) and is your Traffic Accommodation Strategy (TAS) or Traffic Accommodation Plan (TAP) approved?
- Do your temporary traffic control devices properly protect the work area? Are traffic and pedestrian movements properly separated?
- Are all City regulations and rules for on street construction being observed?
- Have you contacted "Alberta 1 Call Corporation" 1-800-242-3447 for utility location? Have you contacted any other necessary companies who are NOT part of "1 Call"?
- For all O.S.C.A.M. permit requests involving excavation for underground utility installations, and/or above ground pedestals on road right-of-way, excluding gas, water and sewer services, a Utility Line Assignment (ULA) Permit No. must be supplied. For more information on the ULA Permit process, call Transportation Department, road right-of-way management at 780-944-7694.
- Have you notified in writing (ie. bulletins), the surrounding businesses and residents near or adjacent to your proposed work area?
- Are you working at a "three year no cut" location? If so, have you obtained the proper exemptions please call 780-944-7694 for three year no cut exemptions.
- If you are working on a bus route and impacting bus service, have you contacted Edmonton Transit at 780-945-4661?
- Do you plan to work outside the permitted hours of work under The City of Edmonton noise bylaw? If yes, you must apply for a noise bylaw waiver at 780-496-3100.
- If you are working at a signalized intersection, are the signal timings adjusted to optimize traffic flow?

STANDARDS OF PERFORMANCE

All work to be done on City streets shall meet the policies and procedures of the City of Edmonton. All work on City streets shall:

- First be approved by the Manager of Transportation Operations Branch or his approved designate, who will assist in coordinating the traffic changes required for the work proposed.
 - a) If the construction work will significantly impact traffic conditions, OSCAM permit application must be received at least ten (10) working days prior to the start of work.
 - b) Work that alters but does not change traffic flows must be approved at least two (2) working days prior to the start of work.
 - c) All emergency work shall be reported immediately to the Transportation Operations Branch by telephone at 780-442-6458 or after hours at 311.
- Transportation Operations shall ensure that City rules, regulations and guidelines are followed by all contractors.
- All work areas shall be properly signed and barricaded to the satisfaction of the Transportation Operations Branch until normal conditions are restored.
- After the Temporary Traffic Accommodation Plan is approved by Transportation Operations it is the responsibility of the prime contractor or the job site supervisor to arrange, maintain and monitor Temporary Traffic Control.
- Records shall be maintained of placement and movements of all Temporary Traffic Control Devices by City or private contractor and shall be available upon request by Transportation Operations Branch.
- The rush hours in Edmonton are typically from 07:00 to 09:00, and from 15:30 to 18:00, Monday through Friday excluding holidays. During these times work is not allowed on the main streets except in emergencies or where Transportation Operations approval has been granted through an OSCAM permit.

- When traffic lanes are required before the work is finished, trenches and small excavation sites shall be bridged with steel plates. All unnecessary Temporary Traffic Control equipment and devices shall be removed from the road or turned away from traffic immediately.
- For total closures and all major disruptions, all affected businesses and residents shall be notified by the contractor in writing 10 working days prior to the commencement of work.
- Work on main roads should be done during night time hours and on weekends whenever possible.
- Private vehicles are not to be parked on work sites or at hooded meters.
- Roadways shall not be obstructed with piles of material, unless otherwise approved by Transportation Operations and shall be barricaded with proper Temporary Traffic Control.

Did You Know?

- O.S.C.A.M. permit numbers must be available to view onsite at all times.

O.S.C.A.M. PERMITS

When you apply for an O.S.C.A.M. permit it is important that you provide as much detail as possible.

- Proposed start/completion date
- Details regarding proposed lane or sidewalk closures
- Restoration required and by whom

On-Street Construction and Maintenance (O.S.C.A.M.) permits are required for:

- (a) All work that involves excavation of roadways, sidewalks, or boulevards.
- (b) Non-excavation work that interferes with traffic flows on major roadways during the hours of 07:00 - 09:00 and/or 15:30 - 18:00 excluding weekends and holidays.
- (c) All work on freeways, river crossings, or in the downtown core.
- (d) All work with a duration of more than four hours at one location.

It is the responsibility of the customer to accurately maintain the start and completion dates of the O.S.C.A.M. permit. Working without a valid and accurate permit is in violation of Traffic Bylaw 5590 and subject to fine and/or removal from the road right of way.

O.S.C.A.M. permits can be obtained by phoning 780-442-6458 or after hours at 311.

PARKING BANS

When Temporary Traffic Control devices or the work site are obstructed by parked vehicles, temporary parking restrictions may be required.

Temporary "No-Parking" signs should be installed as follows:

- Mounted on portable A-Frames installed along the entire length of the desired zone and spaced approximately 20 to 30 metres apart.

Typical Parking Ban Installation

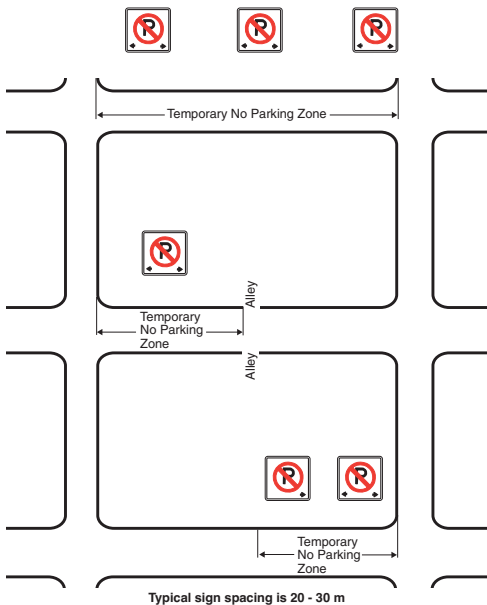

- Regulatory "No-Parking" signs shall be used. Homemade signs are not acceptable and are not enforceable.
- The zone must have a defined beginning and end. The beginning or end is made up of an intersecting back lane, street or avenue. Private driveways are not considered beginning or ends of "No-Parking" zones.
- A "No-Parking" record form must be filled out by an onsite representative when the signs are installed and then forwarded to Transportation Operations. This form records the license plate numbers of any vehicles parked at the location prior to the signs being installed.
- After 72 hours has passed a vehicle can be tagged and towed at the owners expense. A vehicle may be courtesy towed at any time by an authorized City of Edmonton representative. A courtesy tow is done at the expense of the on site agency who is requesting the temporary parking restriction.

PARKING METERS

Parking bans at locations where parking meters are present are installed by Transportation Operations. In this situation signs are not installed but instead the parking meters are hooded so that they are no longer in effect. The Transportation Operations section is the only agency that can install this type of parking ban. Requests for parking meter hoodings should be made to the Transportation Operations section a minimum of two (2) working days in advance of the proposed start of construction.

PEDESTRIAN OBSTRUCTIONS

In situations where work is taking place on a sidewalk, steps must be taken to ensure the safety of pedestrians. All pedestrian facilities must be installed to the satisfaction of Transportation Operations.

- Where trenches or excavations are placed on sidewalks a pedestrian bridge complete with handrails shall be installed.
- When work is taking place adjacent to a sidewalk, precautions must be taken to ensure that there is no danger to pedestrians from above. This may include hoardings or scaffolding.
- When a sidewalk must be closed and it is not possible to send pedestrians to the other sidewalk a proper closure of the adjacent curb lane may be used to provide pedestrians with a temporary sidewalk. A minimum sidewalk width of 1.5 metres is required at all times for temporary conditions.
- When a sidewalk must be closed it should be closed and properly signed at the nearest intersection. This allows pedestrians to use the sidewalk on the opposite side of the road rather than allowing pedestrians to come to the worksite.
- When pedestrians are directed to temporary walks, adequate ramping must be installed to facilitate mobility and devices.

GUIDE TRAFFIC AROUND THE WORK AREA

The protection of the work area and the maintenance of traffic flows around construction sites is done by placing various signs, barricades, mini barriers or traffic cones in certain positions. In some cases it may be necessary to use flagpersons. As each situation will be different, contractors will determine the requirements for suitable site protection.

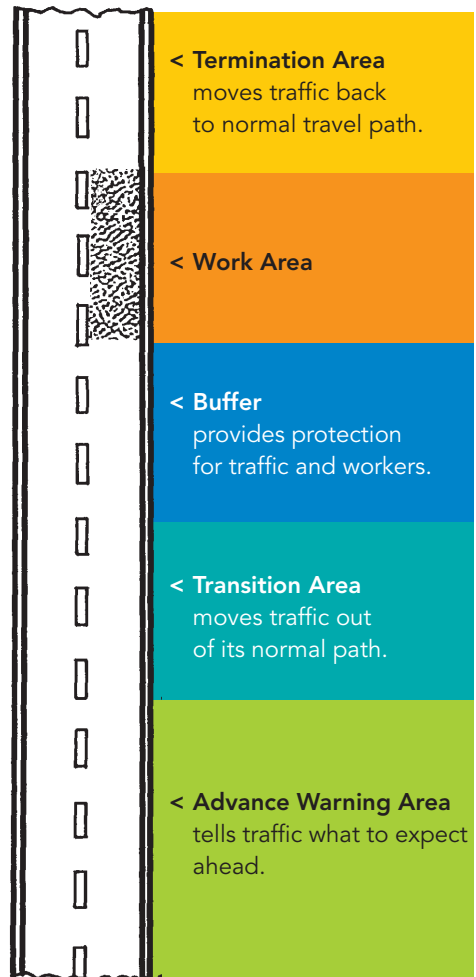

Information and Detour Guide Signs

Signs are necessary for controlling, warning or guiding traffic through or around a work area. Signs shall be mounted approximately at right angles to and facing the flow of traffic. Each sign shall carry one message. Signs must be placed such that the message is clear. Information signs are required for major road closures and major road work.

Signs to be used after daylight hours must be made of reflective material. Illustrations of the various signs have been provided on the following pages.

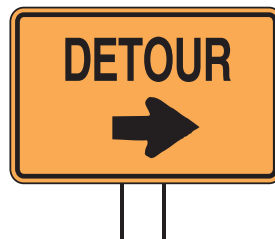
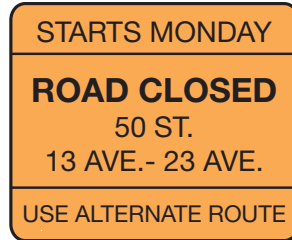
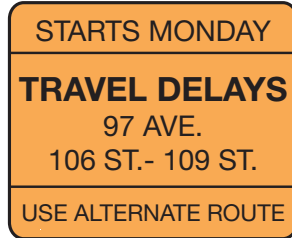

Regulatory Signs

Note: Installed and removed only under the authority of Transportation Operations.



Stop



Maximum 60 km/hr



60 km/hr Ahead



Yield



One Way



Do Not Enter

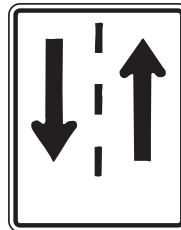

Two Way Traffic



No Parking



Keep Right



No Left Turn

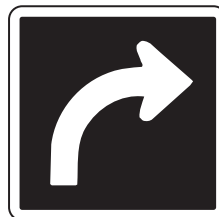

Right Turn

Advance Warning and Temporary Condition Signs

Must be made of minimum fluorescent orange diamond grade (DG3) material. All signs are 75x75 cm for speeds up to 70 km/hr and or 90x90 cm for speeds of 80 km/hr and greater.



Speed Advisory



Curve Warning



Note: To be used only when workers are present.



Bump



This sign shall be displayed only when a flagperson is actively controlling traffic.



Highway Divider



Trucks Crossing



Right Lane Ends



Pavement Drop Off

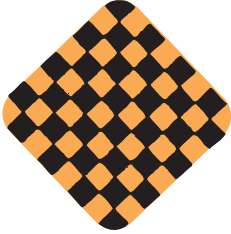

Checkerboard



Signals Ahead



Barricades

Reflective barricades shall be used to outline work area obstructions. Barricades shall not be used in place of a sign. They must never be placed in the line of traffic without advance warning signs.

Some good examples of barricades and typical situations in which certain barricades are used as described on this page.

Worksite Barricades

Used to delineate work areas and to identify a specific hazard.

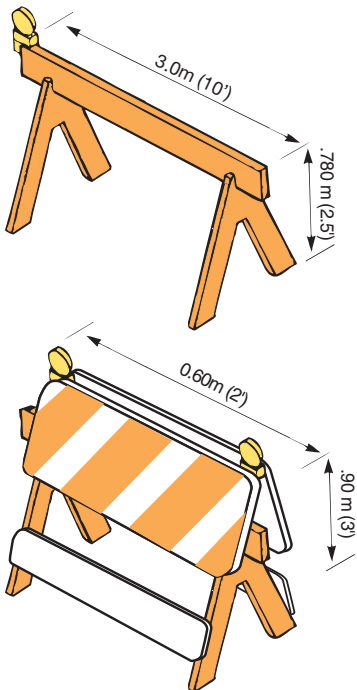

Traffic Control Barricade 2.4m long

Used to close streets, provide buffer zones and delineate work area obstruction. Traffic Control Barricades must be effective for night time visibility. (minimum reflectorization = 2500 sq.cm. DG3 in a reasonable state of repair)

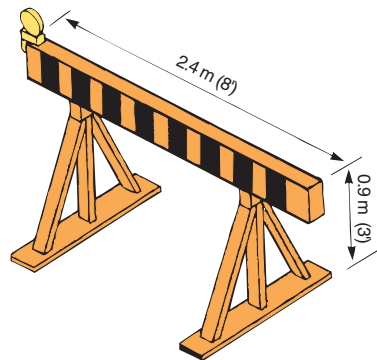

Precast Mini Barriers

Used to close streets and separate traffic through construction zones. Nose sections shall be used at either end of mini barrier facing traffic.

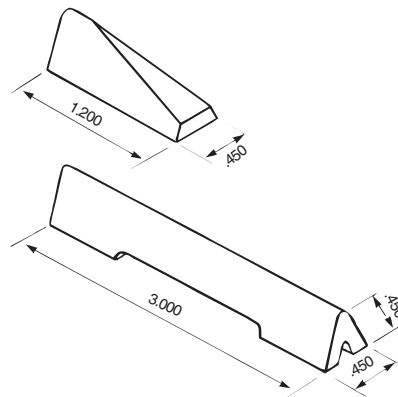

A-Frame

Typically used to mount "TEMPORARY NO PARKING" signs, and "ADVANCE" warning signs (with flags).

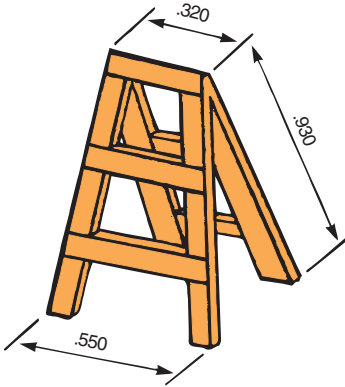

90 x 30 cm



90 x 45 cm



90 x 30 cm

CHANNELIZATION DEVICES

Channelization is a method of gradually reducing the width of a road while maintaining the flow of vehicles. Typically channelization involves closing a travel lane and merging traffic into the adjacent lane. Channelization may also involve shifting traffic from an existing lane to a detour lane or from a road to a detour road without reducing the actual number of travel lanes.

Channelization devices are placed in series along a taper or along the length of a worksite to guide motorists around the worksite. Different channelization devices are suited to specific situations. Any devices which are used at night must be reflectorized or illuminated to show the same shape and color by night as by day.

Cones

Cones are used in the taper of a lane closure on short-term daytime jobs and can be used for night work if they have high intensity reflective material striping. The 1.0m cones or tubes may be used as temporary separation for opposing directions of traffic. Use of these cones or tubes shall meet the following speed guidelines:

Cone Height Minimum: Roadway Speed

- 18 Inches (0.45 m): 60 Km/h or less
- 28 Inches (0.70 m): 0 to 110 Km/h

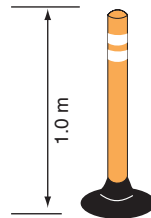
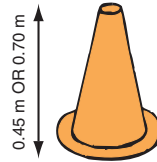

Chevrons or Vertical Panels

Vertical panels can be used in the taper of a lane closure on a long term job or along the edge of a road to outline the travel path. They may also be used to separate opposing directions of traffic provided that they are placed back to back. The panels may be accompanied by flashers or steady burn lights. Vertical Panels and Chevrons must be made of high intensity reflective material.

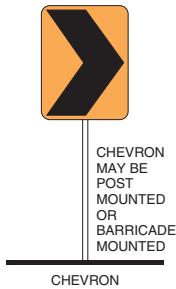

Flexible Drums

Flexible Drums are used on long term projects or in high speed locations within the taper areas or along the edge of the road to outline the travel path. Flexible Drums should be accompanied by steady burn lights to improve night time visibility. Flexible Drums shall have stripes of high intensity reflective material.

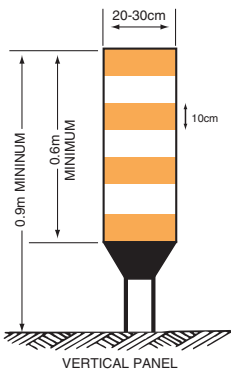

Placement of Channelization Devices

Channelization devices (cones, chevrons, vertical panels, flexible drums) must be placed at a specific spacing along a determined length of taper. The spacing and length of taper is determined by the speed limit of the road. When a lane is closed and traffic is forced to merge into the adjacent lane the taper is called a merging taper. When a taper is used to guide traffic but not reduce the number of travel lanes, the taper is called a shifting taper. A shifting taper is equal to one half the length of a merging taper for an equal speed.

Speed Limit (km/h)	Spacing Between Signs (m)	Length of Taper (m)	Length of Longitudinal Buffer Space (m)	Spacing Between Delineation Devices (m)
50	50	30	35	8
60	50	40	45	12
70	75	60	50	15
80	100	80	60	15
90	100	105	65	18
100	125	125	70	18
110	125	145	75	20

Arrowboards

Arrowboards when combined with Advance warning signs and delineation devices, are especially useful in situations which require higher than normal visibility.

Examples where Arrowboards should be used are on overnight setups, high speed and high volume roadways (70km/h and greater) and in poor weather conditions.

- Recommended minimum size for an arrowboard is 900mm x 1200mm.
- Light bars on vehicles maybe used in emergency situations, or when posted speeds are 60km/h or less.



Arrow Pattern



Chevron Pattern

Specialty and Lighting Devices

Amber Flashers or Strobes

To be used on vehicles and equipment in addition to the warning signing and channelization devices.

Amber flashers should also be used on light barricades to increase visibility of hazards.



Steady Burn Lights

To be used on channelization devices such as drums or vertical panels. These devices are used to supplement channelization devices to provide better night time guidance for motorists.



Flags

Flags are used on ground mounted warning signs to improve their visibility. The total height of the warning sign and the flags should be a minimum of 2m.



FLAGPERSON DUTIES AND RESPONSIBILITIES

Flagpeople have a vital job being the front-line contact with the public. In this capacity, flagpeople must be alert and courteous. Flagpeople must understand their duties and be able to signal to drivers, so that drivers understand their directions.

Flagperson procedures differ between various types of construction projects. The flagperson must continually adapt procedures to accommodate the safe flow of traffic around a construction site.

The following section is a brief overview of flagging procedures, responsibilities and equipment. Any individual who will be acting as a flagperson on a regular basis must be properly trained in flagging. To obtain information regarding the flagperson training course you may contact the Alberta Construction Safety Association (ACSA) or the Safety and Equipment Training Section of the City of Edmonton Transportation Department.

Equipment

A flagperson must wear a hard hat, appropriate clothing and an appropriate safety vest with reflective striping on the front and back. The safety vest should always be worn on the outside of all clothing. Optional white coveralls may be used.

A standard Stop/Slow paddle, either hand held or pole mounted should be used for day time use. For night time work a flashlight with a semi-transparent red cone or an illuminated paddle should be used. Flags should only be used in emergencies.

Communication devices should be used when visual contact between flaggers cannot be maintained.

Signaling Procedures

Signaling equipment shown below must be kept in good condition.

The figures below illustrate the various hand signals to be used by flagperson for controlling traffic. It is important to be clear in your signaling and to stand so that oncoming traffic has a clear view of the appropriate signal.

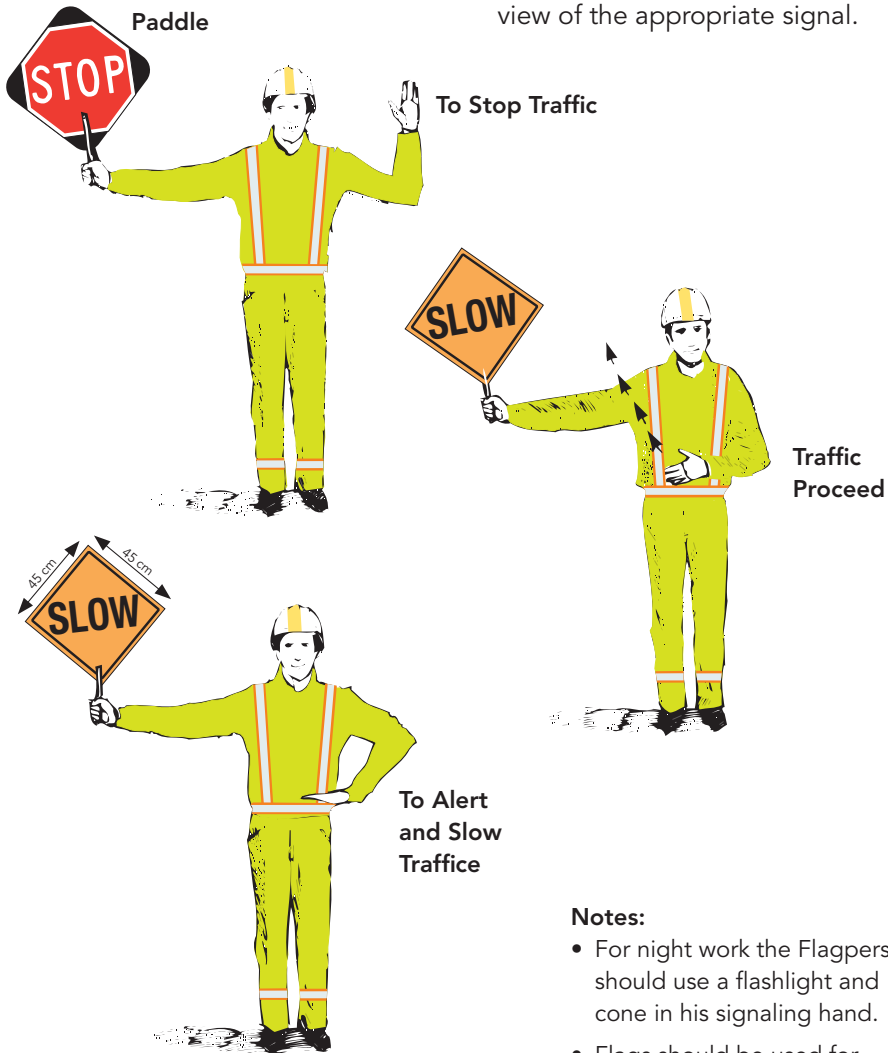

Notes:

- For night work the Flagperson should use a flashlight and cone in his signaling hand.
- Flags should be used for emergency situations only.

- Keep the stop/slow sign held high, in the line of sight for approaching drivers.
- Make direct eye contact with the driver.
- Use your free hand to signal to the driver. Do not swing or wave the stop/slow sign.
- Give drivers time to react to your signals. Give them more time to react if the speed of the traffic is high or if the weather and/or visibility is less than ideal.
- Never stand directly in front of oncoming traffic. If stopping traffic, move to the centre line after the first vehicle has stopped.
- Never turn your back on traffic.
- Follow the previous illustration on page 25 to stop, slow or release traffic.
- At traffic signals, the traffic should be stopped at the same time as the red signal is showing. Do not stop traffic on a green signal.

Positioning

- Plan your route for escape.
- Stand outside the lane of traffic.
- Stand an appropriate distance from the work zone which will allow you to protect worksite personnel. This position will vary depending on the type of work that is taking place, the speed limit of the road and the weather conditions.

Checklist

- Is the “flagperson” sign up and far enough ahead of the flagperson?
- Have the remainder of the traffic control devices been placed?
- Have arrangements been made for necessary break times?
- Is the equipment clean, visible and in good condition?
- Has an escape route been planned? What about fellow workers?

PROCEDURES FOR PROSECUTION OF VIOLATIONS AGAINST FLAGPERSON

In cases where motorists endanger or threaten flagpeople it is important that as much information as possible be recorded to prosecute the offending party. The Police cannot prosecute these individuals if they do not have sufficient evidence.

1. Gather the following information:
 - Licence plate number
 - Color and make of vehicle
 - Description of driver
 - Time of offence
 - Names and phone numbers of witnesses
2. Contact the Edmonton Police Service at 780-423-4567 or 911 in the event of an emergency and inform them of what happened. If there have been any injuries request that an ambulance be dispatched. The Police will either dispatch a car or have you go to the nearest station to file a complaint.
3. Contact your company or department safety officer and inform him of the offence.
4. Make detailed notes of the incident as soon as possible while the incident is fresh in your memory. These notes will be useful if you are required to testify in court.
5. It will be up to you to file a complaint with the Police. Your department or company cannot do this for you, however your safety officer can accompany you to assist.
6. The Police will determine which charges can be laid and whether or not you have sufficient evidence based on the information that you provide to them. If there is sufficient evidence the Police will lay the appropriate charges against the offender.
7. If the Police lay charges you may be required to attend court to supply evidence.
8. If the Police feel that there is insufficient evidence to lay charges you may proceed with civil action against the offender by contacting the Clerk of the Court. They will arrange to meet with you to discuss your case.
9. If your company or department utilizes a near-miss or accident/incident investigation report complete as required.

TEMPORARY TRAFFIC CONTROL

Record Keeping

Records shall be kept by the jobsite supervisor for any work which is interfering with traffic. These records are required in case of an accident at or near the worksite which could result in legal action against the company performing the work and its workers.

Temporary Traffic Control records should be made at the time of the initial set-up and should include either a sketch, photograph or video of the worksite traffic controls. For jobs which remain in place for more than one day a daily inspection record shall also be maintained.

The Temporary Traffic Control Record should include the following:

- O.S.C.A.M. permit #
- Location
- Weather Conditions
- Start date and time of Temporary Traffic Control set-up
- Time of arrival on site (For detours set by others)
- Job site supervisor's name and department or company
- Who set up the Temporary Traffic Control (Example: Transportation Operations or yourself)

- Sketch or photograph of the Temporary Traffic Control devices.
- Time of removal of the Temporary Traffic Control. Remember to turn unnecessary advance warning signs away from traffic.

The Daily Inspection Record should include the following:

- Time of arrival on site
- Condition of Temporary Traffic Control at time of arrival
- Note of any damaged or missing traffic control devices
- Steps taken to correct deficiencies (Example: Contacted Transportation Operations for replacement of damaged barricades)
- Time of departure and condition of temporary traffic controls
- Steps taken to secure the worksite.

These records should be kept by anyone who is working in traffic. The records should either be kept in the job site supervisor's daily log or in a standard record form from your company or department.

Guideline for Work Zone Speed Reductions

1. All requests for Work Zone speed reductions shall be submitted to:
City of Edmonton
Transportation Operations Branch
Traffic Control Section
15th Floor Century Place
9803 102A Avenue
Edmonton, AB T5J 3A3
Fax: (780) 496-1757
2. Unless otherwise indicated, all requests shall include:
 - a) A diagram of proposed work zone and proposed placement of work zone speed reduction signs.
 - b) A list of identified hazards that require a work zone speed reduction. In order to be effective, work zone speed reductions must be supported by visual evidence from a motorist's perspective. Examples may include but are not limited to:
 - Workers adjacent to moving traffic,
 - Change to roadway geometry that makes travel at existing speeds unsafe,
 - Deep excavations in close proximity to moving traffic,
 - Narrow lane widths,
 - Sight distance restrictions.
 - c) Other proposed actions to be taken by Prime Contractor to manage speed reduction within work zone (i.e. flagperson control, electronic speed display board, lane reduction, lane narrowing, etc).
3. The City of Edmonton, Transportation Operations Branch, must approve all work zone speed reduction locations prior to implementation.
4. Unless otherwise approved, Maximum Speed Ahead (RB-05) and Construction Zone Maximum (WD-AE10) signs shall be used to define work zone speed reduction areas. Construction Zone Ends (WD-AE7) shall be used to identify end of work zone speed reductions.
5. Speed limits shall be reduced in increments of no greater than 30 km/h. Too large of a speed reduction creates a hazardous difference in speed between vehicles, and increases the potential for collisions.



6. Unless otherwise indicated, The City of Edmonton, Transportation Operations Branch shall always do the initial setup of work zone speed reductions.
7. After installation, Prime Contractor shall be responsible for monitoring and maintaining work zone speed reduction signs.
8. Approved work zone speed reductions shall be installed as one of two types of speed zones. They are as follows:
 - a) **Temporary Speed Zone**

For worker safety, temporary speed zones are established and are in effect only when workers are present and activity is adjacent to moving traffic.
 - b) **Construction Speed Zone**

Temporary speed limit in a construction intended for a 24-hour continuous posting. Generally established for long term projects where it is imperative for motorists to reduce speed to safely navigate through hazards over the length of a project. The primary reason to establish the construction speed zone should be present 24 hours a day.

9. Unless otherwise indicated by the City of Edmonton, Transportation Operations Branch, all approved work zone speed reductions shall be Temporary Speed Zones. This includes Speed Fines Double in Construction Zones, Begins and Speed Fines Doubles and Ends signs will define the zone.



10. Prime Contractor shall be responsible for removal or covering of temporary speed zone signs and speed fine doubles signs when no workers are present. This includes the re-installing or uncovering of existing speed limit signs.
11. All actions taken by the contractor shall be recorded on a "Record of Temporary Traffic Control" form or other acceptable alternative as approved by the City of Edmonton, Transportation Operations Branch.
12. All records shall be forwarded monthly to the City of Edmonton, Transportation Operations Branch.
13. Non-compliance with the above guidelines will result in the Prime Contractor receiving written notification of event. Subsequent events of non-compliance will result in removal of "Work Zone Speed Reduction" signs.

Note

Work Zone Speed Reductions must be removed or covered when not justified. If a reduced speed zone has been left posted while the site is inactive, such as weekends, evenings, etc., then the signs lose effectiveness with repeat traffic. This loss in effectiveness can be carried from one project to another.

SYMBOLS USED IN TYPICAL SITUATION SKETCHES

Signs

Symbol



Actual



Barricades

Symbol



Mini-barrier

Actual



Traffic control barricades and directional arrow



Worksite or light barricades

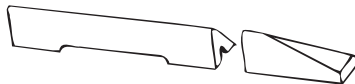

Precast mini-barrier and mini-barrier nose

Channelization Devices

Symbol

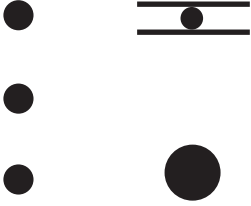

Actual

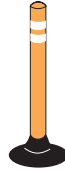

Tubes



Vertical Panel

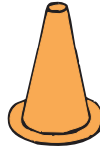

Cones

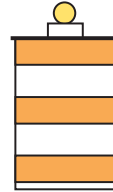

Drums or Barrels

Lighting and Specialty Devices

Symbol



Actual



Beacon



Flasher



Arrowboard



Flags

EXAMPLES OF TYPICAL WORKSITE TRAFFIC CONTROL SET-UPS

This section of the Procedures Manual contains examples of traffic situations where the use of signs, barricades, protective devices, cones and/or flagperson are necessary.

The examples shown in the next few pages are not an overall guide to every possible traffic situation where signs or other devices are needed. Rather, the illustrations show a few of the more common everyday situations and they are to be used as a guide only. Common sense will determine the best action to be taken.

Remember that the protection of the public and the workers at any worksite can often depend on the protective equipment used to alert traffic to any obstructions.

Included in the following pages are examples of the following situations:

- Series (A) complete and partial road closures
- Series (B) flagging and short duration operations



Series A Complete And Partial Road Closures

This section refers to those situations where complete or partial closures of a road are necessary for the protection of the public or workers. Different ways of closing a road may be used. These are illustrated in the sketches following. In those cases where a different route for traffic is not obvious, detour signs may be required.

Examples:

- A1 – Back Lane Closure
- A2 – Residential Road Closure
- A3 – Yield to Oncoming Traffic
- A4 – Single Left Lane Closure: Parking Permitted
- A5 – Single Single Lane Closure: No Parking Permitted
- A6 – Sidewalk Closure with Pedestrian Accommodated Lane Closure
- A7 – Two Lane Closure: Traffic Split

The examples that follow use the information shown in the chart below.

(V) Speed Limit (km/h)	(A) Spacing Between Signs (m)	(L) Length of Taper (m)	(B) Length of Longitudinal Buffer Space (m)	(D) Spacing Between Delineation Devices (m)
50	50	30	35	8
60	50	40	45	12
70	75	60	50	15
80	100	80	60	15
90	100	105	65	18
100	125	125	70	18
110	125	145	75	20

A1 – Back Lane Closure

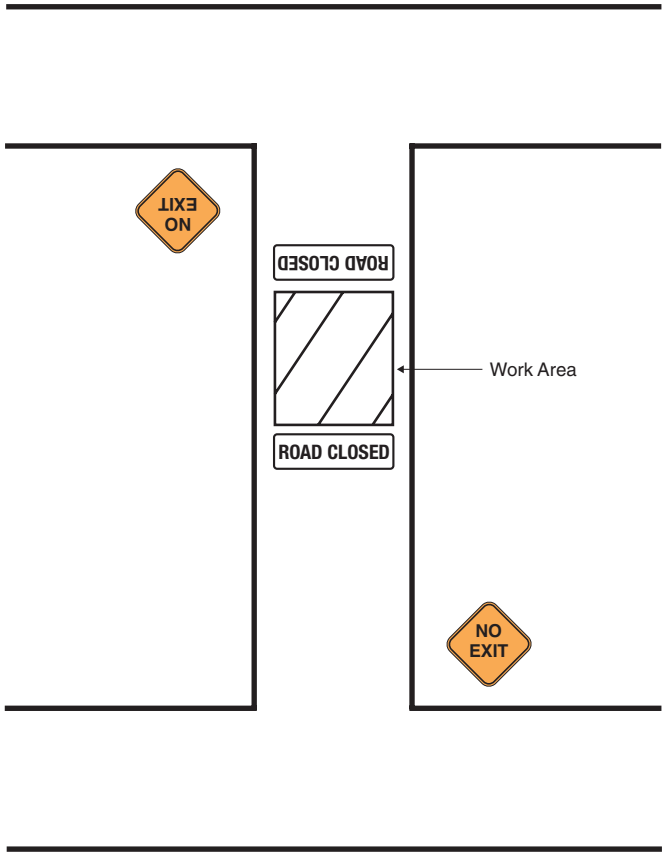

(V) Speed Limit (km/h)	(A) Spacing Between Signs (m)	(L) Length of Taper (m)	(B) Length of Longitudinal Buffer Space (m)	(D) Spacing Between Delineation Devices (m)
50	50	30	35	8
60	50	40	45	12
70	75	60	50	15
80	100	80	60	15
90	100	105	65	18
100	125	125	70	18
110	125	145	75	20

A2 – Residential Road Closure

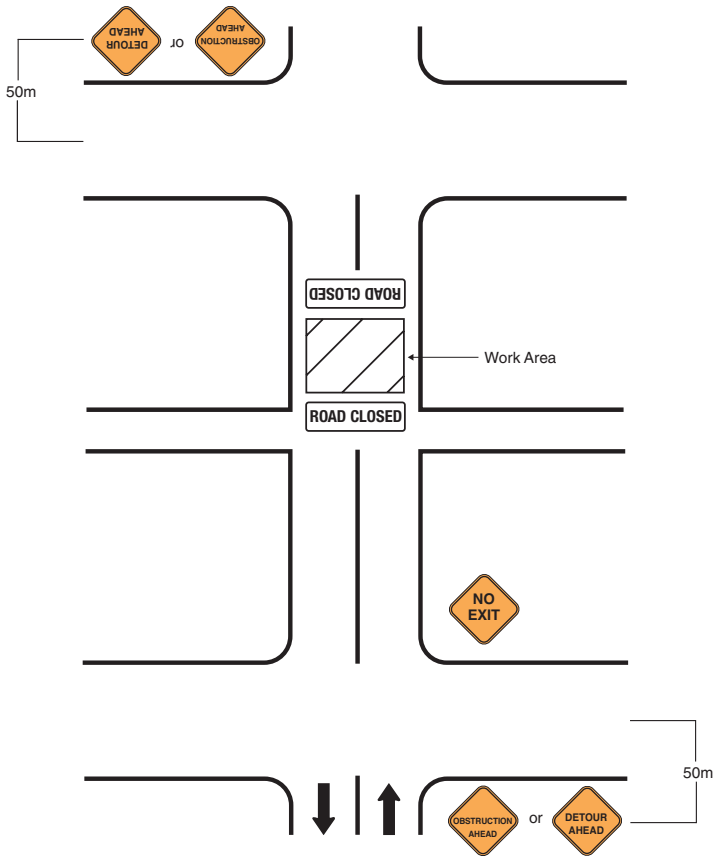

(V) Speed Limit (km/h)	(A) Spacing Between Signs (m)	(L) Length of Taper (m)	(B) Length of Longitudinal Buffer Space (m)	(D) Spacing Between Delineation Devices (m)
50	50	30	35	8
60	50	40	45	12
70	75	60	50	15
80	100	80	60	15
90	100	105	65	18
100	125	125	70	18
110	125	145	75	20

A3 – Yield to Oncoming Traffic

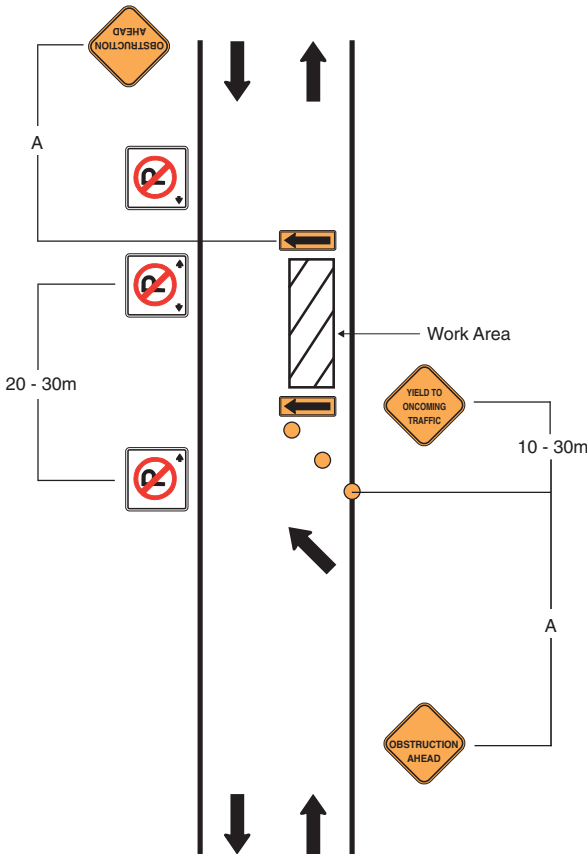

(V) Speed Limit (km/h)	(A) Spacing Between Signs (m)	(L) Length of Taper (m)	(B) Length of Longitudinal Buffer Space (m)	(D) Spacing Between Delineation Devices (m)
50	50	30	35	8
60	50	40	45	12
70	75	60	50	15
80	100	80	60	15
90	100	105	65	18
100	125	125	70	18
110	125	145	75	20

A4 – Single Left Lane Closure: Parking Permitted

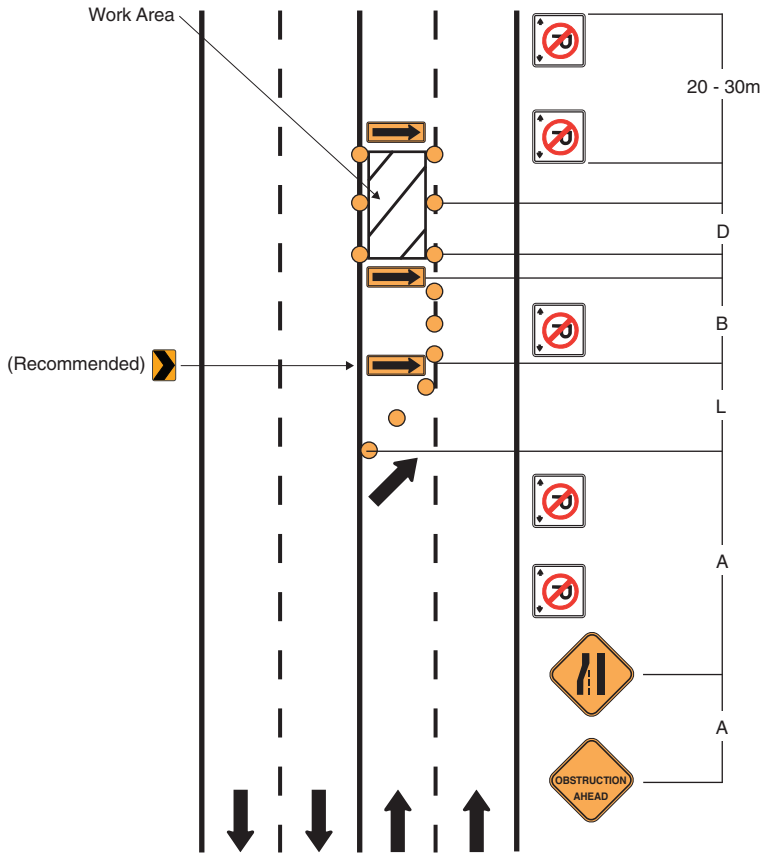

(V) Speed Limit (km/h)	(A) Spacing Between Signs (m)	(L) Length of Taper (m)	(B) Length of Longitudinal Buffer Space (m)	(D) Spacing Between Delineation Devices (m)
50	50	30	35	8
60	50	40	45	12
70	75	60	50	15
80	100	80	60	15
90	100	105	65	18
100	125	125	70	18
110	125	145	75	20

A5 – Single Right Lane Closure: No Parking Permitted

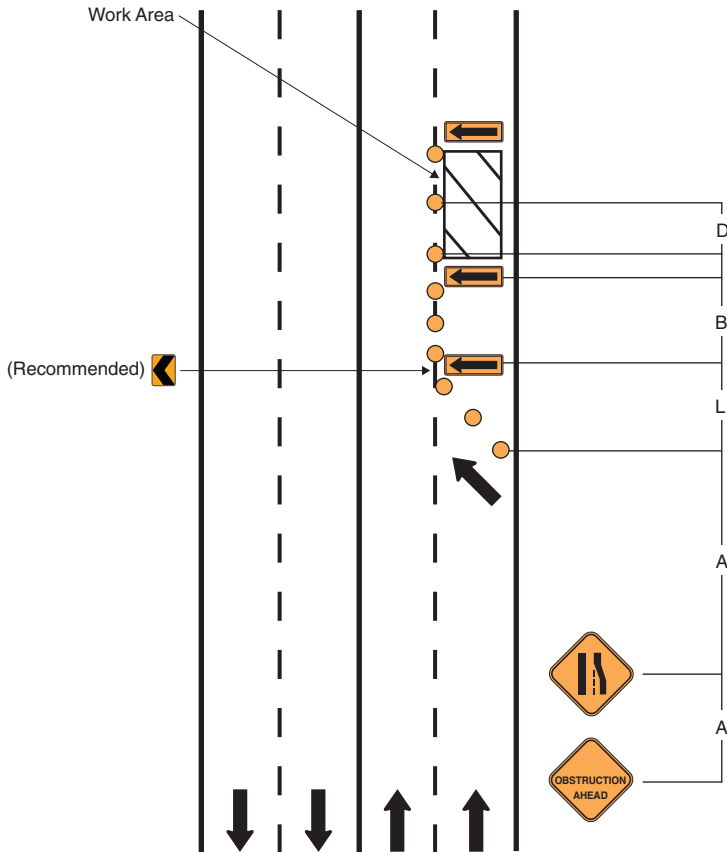

(V) Speed Limit (km/h)	(A) Spacing Between Signs (m)	(L) Length of Taper (m)	(B) Length of Longitudinal Buffer Space (m)	(D) Spacing Between Delineation Devices (m)
50	50	30	35	8
60	50	40	45	12
70	75	60	50	15
80	100	80	60	15
90	100	105	65	18
100	125	125	70	18
110	125	145	75	20

A6 – Sidewalk Closure with Pedestrian Accommodated Lane Closure

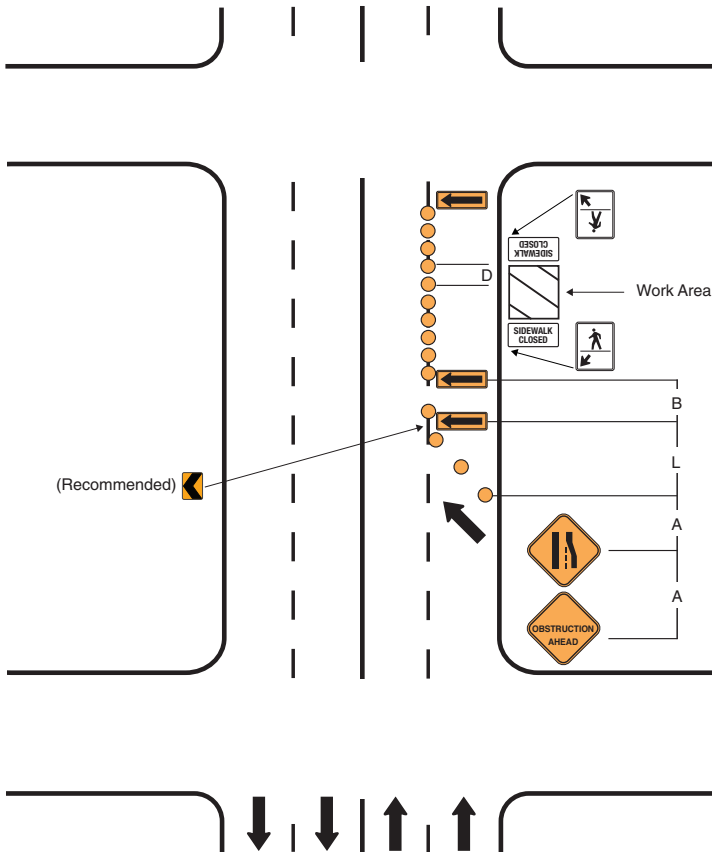

(V) Speed Limit (km/h)	(A) Spacing Between Signs (m)	(L) Length of Taper (m)	(B) Length of Longitudinal Buffer Space (m)	(D) Spacing Between Delineation Devices (m)
50	50	30	35	8
60	50	40	45	12
70	75	60	50	15
80	100	80	60	15
90	100	105	65	18
100	125	125	70	18
110	125	145	75	20

A7 – Two Lane Closure: Traffic Split

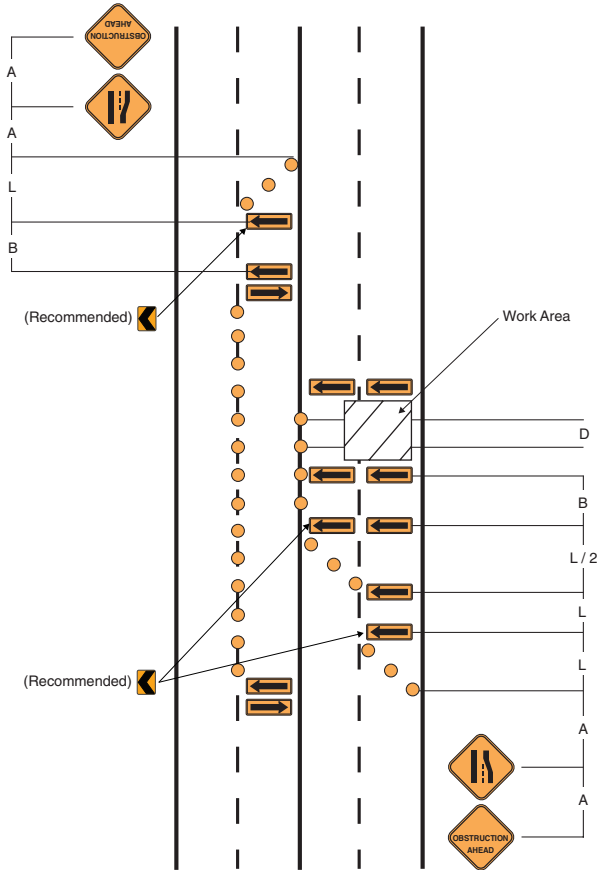

(V) Speed Limit (km/h)	(A) Spacing Between Signs (m)	(L) Length of Taper (m)	(B) Length of Longitudinal Buffer Space (m)	(D) Spacing Between Delineation Devices (m)
50	50	30	35	8
60	50	40	45	12
70	75	60	50	15
80	100	80	60	15
90	100	105	65	18
100	125	125	70	18
110	125	145	75	20

Series B Flagging and Short Duration Operations

Flagging and short duration operations can occur under a variety of situations. Included in the following pages are examples of the following situations:



- B1 – Two Way Flagging Operation
- B2 – Flagging:
 Closure Short Duration
- B3 – Short Duration:
 Utility Operation
- B4 – Short Duration:
 Work at Signalized Intersection

The examples that follow use the information shown in the chart below.

(V) Speed Limit (km/h)	(A) Spacing Between Signs (m)	(L) Length of Taper (m)	(B) Length of Longitudinal Buffer Space (m)	(D) Spacing Between Delineation Devices (m)
50	50	30	35	8
60	50	40	45	12
70	75	60	50	15
80	100	80	60	15
90	100	105	65	18
100	125	125	70	18
110	125	145	75	20

B1 – Two-Way Flagging Operation

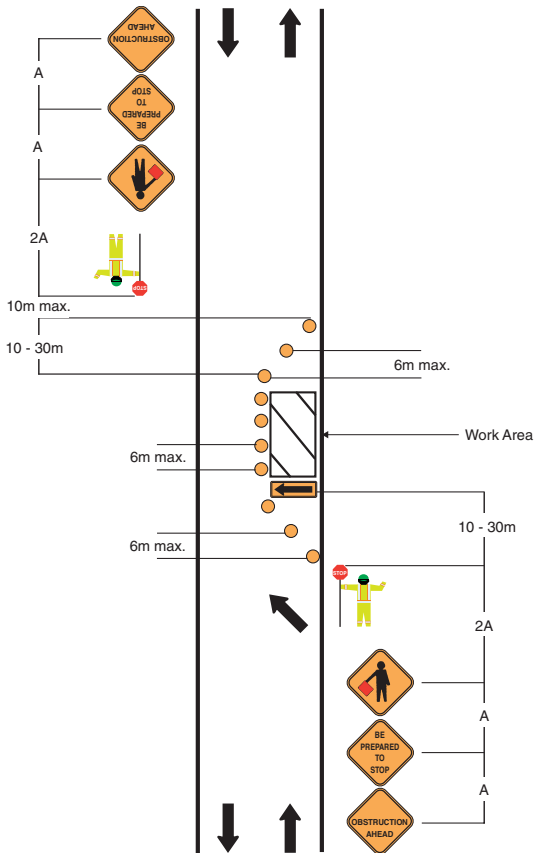

(V) Speed Limit (km/h)	(A) Spacing Between Signs (m)	(L) Length of Taper (m)	(B) Length of Longitudinal Buffer Space (m)	(D) Spacing Between Delineation Devices (m)
50	50	30	35	8
60	50	40	45	12
70	75	60	50	15
80	100	80	60	15
90	100	105	65	18
100	125	125	70	18
110	125	145	75	20

B2 – Flagging: Closure Short Duration

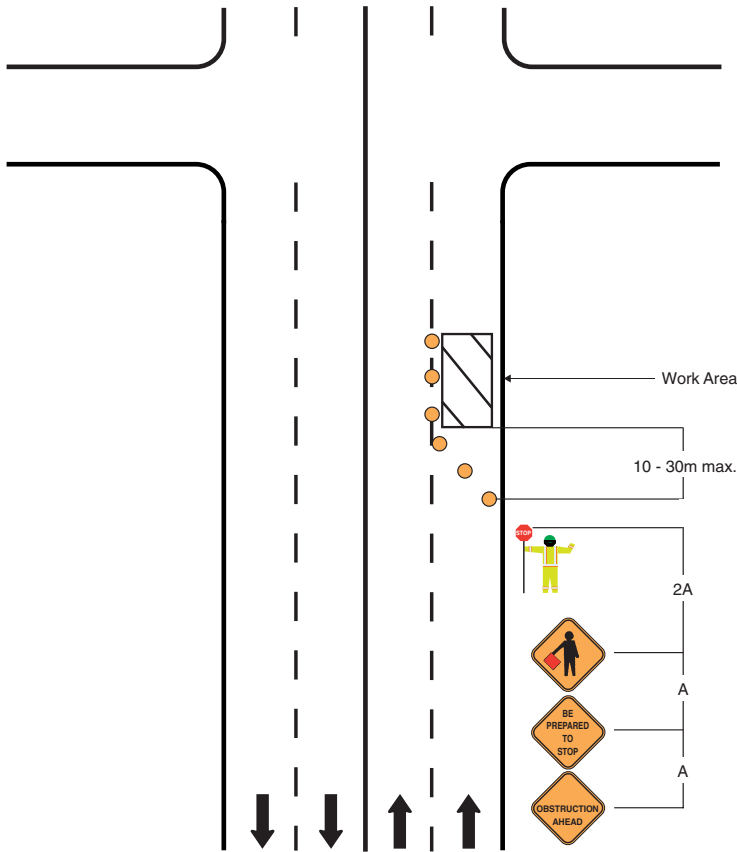

(V) Speed Limit (km/h)	(A) Spacing Between Signs (m)	(L) Length of Taper (m)	(B) Length of Longitudinal Buffer Space (m)	(D) Spacing Between Delineation Devices (m)
50	50	30	35	8
60	50	40	45	12
70	75	60	50	15
80	100	80	60	15
90	100	105	65	18
100	125	125	70	18
110	125	145	75	20

B3 – Utility Operation

(e.g. manholes or pothole repairs, etc.)

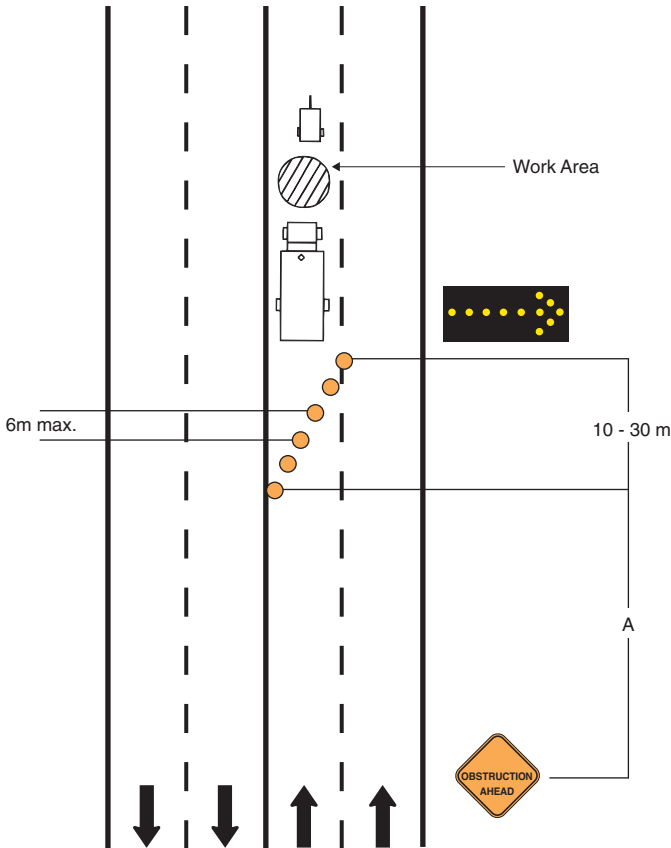

(V) Speed Limit (km/h)	(A) Spacing Between Signs (m)	(L) Length of Taper (m)	(B) Length of Longitudinal Buffer Space (m)	(D) Spacing Between Delineation Devices (m)
50	50	30	35	8
60	50	40	45	12
70	75	60	50	15
80	100	80	60	15
90	100	105	65	18
100	125	125	70	18
110	125	145	75	20

B4 – Short Duration Work at Intersection

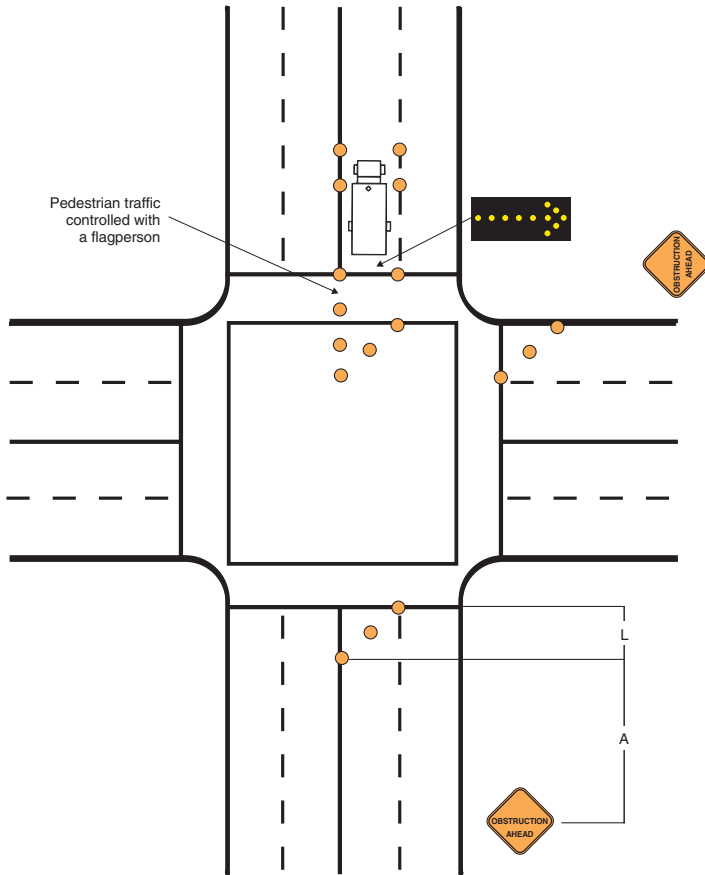

(V) Speed Limit (km/h)	(A) Spacing Between Signs (m)	(L) Length of Taper (m)	(B) Length of Longitudinal Buffer Space (m)	(D) Spacing Between Delineation Devices (m)
50	50	30	35	8
60	50	40	45	12
70	75	60	50	15
80	100	80	60	15
90	100	105	65	18
100	125	125	70	18
110	125	145	75	20

